

# Central

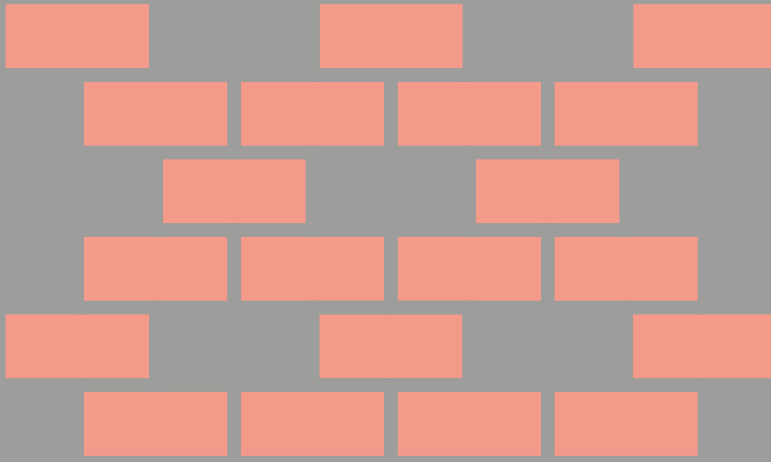

# Area

# Good

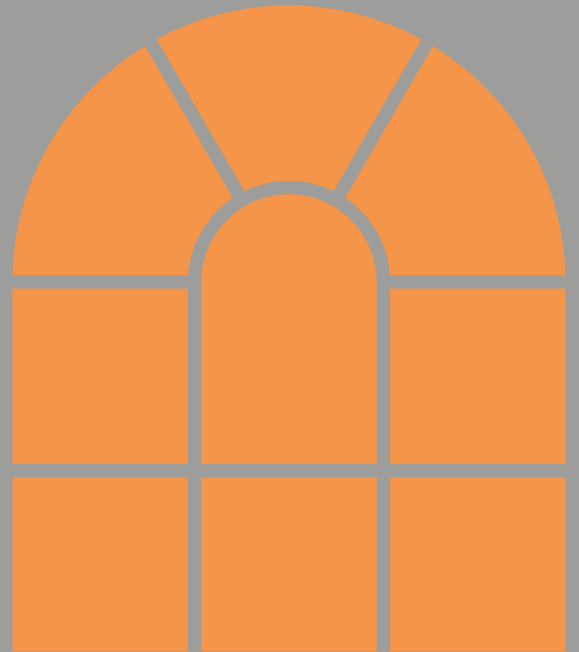
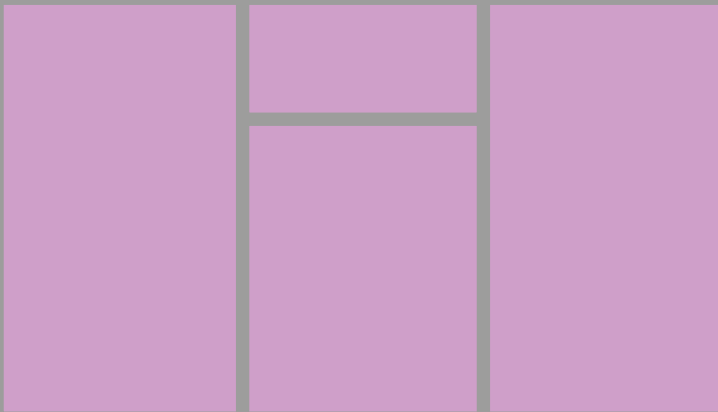

# Growth

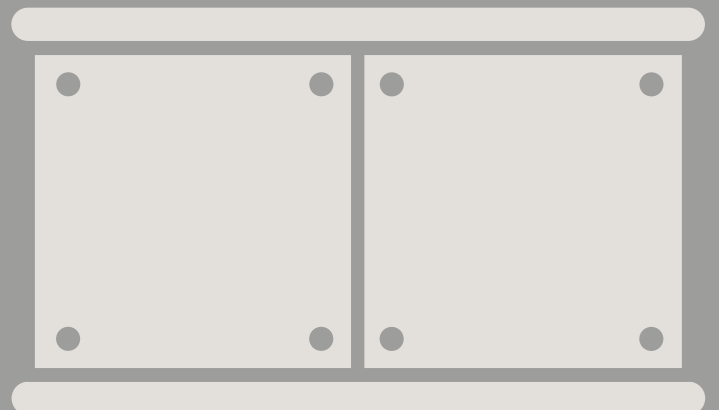

Produced by:

**Place-Shaping Team - Strategic Planning**  
Planning and Building Control Service  
Place Directorate

**Graphic design**  
Maddison Graphic

**Photography**  
Photos on pages 8, 13, 14, 24, 32, 40,  
48, 56, 64, 72, 80, 88, 96, 104, 114 are by  
Ivan Jones. Photos without image sources  
on other pages are by the council. The  
remaining images have their sources/  
authorship individually noted.

# Central Area Good Growth

Supplementary  
Planning Document

August 2021

|   |            |
|---|------------|
| <b>1. Introduction</b>                    | <b>7</b>   |
| 1.1 Overview of the document              | 8          |
| 1.2 Policy context                        | 9          |
| 1.3 How to use this SPD                   | 10         |
| 1.4 How the SPD was developed             | 14         |
| 1.5 Glossary                              | 15         |
| <b>Part A Character appraisal</b>         | <b>21</b>  |
| <b>2. Overview</b>                        | <b>23</b>  |
| 2.1 The Central Area: Setting the scene   | 24         |
| The Central Area: Timeline                | 26         |
| <b>3. Central Area Character Places</b>   | <b>29</b>  |
| 3.1 Introduction                          | 30         |
| 3.2 Bow                                   | 32         |
| 3.3 Bow Common                            | 40         |
| 3.4 Globe Town                            | 48         |
| 3.5 Limehouse                             | 56         |
| 3.6 Mile End                              | 64         |
| 3.7 Poplar                                | 72         |
| 3.8 Shadwell                              | 80         |
| 3.9 Stepney                               | 88         |
| 3.10 Victoria Park                        | 96         |
| 3.11 Wapping                              | 104        |
| <b>4. Central Area housing typologies</b> | <b>113</b> |
| 4.1 Introduction                          | 114        |
| Georgian & Victorian housing growth       | 116        |
| Interwar housing provision                | 120        |
| Postwar 'visionary reconstruction'        | 122        |
| Waterfront housing development            | 126        |
| Late 20th Century urban & suburban        | 130        |
| 21st Century urban housing growth         | 134        |

|  |            |
|--|------------|
| <b>Part B Guidelines for Good Growth</b>                 | <b>139</b> |
| <b>5. Character-based growth principles</b>              | <b>141</b> |
| 5.1 Introduction   | 142        |
| 5.2 Reinforcement  | 144        |
| 5.3 Mediation  | 146        |
| 5.4 Reinvention  | 148        |
| <b>6. Design toolkit for small sites</b>                 | <b>151</b> |
| 6.1 Introduction   | 152        |
| 6.2 How to use this toolkit                              | 153        |
| <b>New build</b>   | <b>156</b> |
| Streetscape infill<br>(between parallel blank gables)    | 156        |
| Corner infill<br>(corner infill site at node)            | 162        |
| Block extension<br>(one blank gable to build off from)   | 168        |
| Garden infill  | 173        |
| Backland<br>(no current access to street)                | 177        |
| Detached site  | 181        |
| <b>Extensions</b>  | <b>184</b> |
| Roof extensions<br>(added to host building)              | 184        |
| Rear extensions<br>(added to host building)              | 188        |
| <b>Other common constraints</b>                          | <b>191</b> |
| Near railway   | 191        |
| Near high-traffic road                                   | 192        |
| Along Thames/canal                                       | 193        |
| In town/neighbourhood centre                             | 194        |
| <b>7. Design principles for residential developments</b> | <b>197</b> |
| 7.1 Introduction   | 198        |
| 7.2 Scale and proportions                                | 199        |
| 7.3 Relationship with street and public realm            | 200        |
| 7.4 Mixed uses & mixed tenures                           | 201        |
| 7.5 Community  | 202        |
| 7.6 Internal spaces                                      | 203        |
| 7.7 External Spaces                                      | 204        |
| 7.8 Amenity: light, privacy & outlook                    | 205        |
| 7.9 Bin and bike storage                                 | 206        |
| 7.10 Materials and detailing                             | 208        |
| 7.11 Sustainable design                                  | 209        |
| 7.12 Embodied energy                                     | 210        |
| 7.13 Sustainable systems                                 | 211        |

# 1. Introduction

## 1.1 Overview of the document

Tower Hamlets has the highest target for new homes in the London Plan 2021. The Tower Hamlets Local Plan 2031 sets out how the borough will grow and develop in the next 10 years. It highlights the importance of developing neighbourhoods with high-quality buildings and well-designed spaces, whilst ensuring a sensitive integration of old and new in order to preserve existing character.

In order to positively manage development opportunities and the growth expected to occur over the next decade, the Tower Hamlets Local Plan 2031 identifies four sub-areas within the borough, three of which are Opportunity Areas. The Sub-Area: Central, is the only one that is not an Opportunity Area. However, in order to meet future needs, the Central Area needs to accommodate 7,597 new homes, or 14% of the borough's total, during the plan period.

The Central Area Good Growth Supplementary Planning Document (SPD) provides guidance to help the council deliver this housing growth, focusing specifically on design guidance to ensure that new developments respect and enhance the well-established character of this part of the borough.

In addition to helping the council deliver its vision for the Central Area, the SPD also supports Priority 2 of the Mayor's Strategic Plan:

Priority 2: A borough that our residents are proud of and love to live in

- People live in a borough that is clean and green
- People live in good quality affordable homes and well-designed neighbourhoods
- People feel safer in their neighbourhoods and anti-social behaviour is tackled
- People feel they are part of a cohesive and vibrant community



## 1.2 Policy context

With a well-established and sensitive character, and limited opportunities for significant redevelopment, the Central Area will go through a gradual intensification, mainly through housing developments on small sites. These may include roof/rear extensions to existing buildings, estate infills and new build developments.

National and regional planning policy and guidance have increasingly highlighted the importance of unlocking small sites in order to meet local and strategic housing requirements.

The National Planning Policy Framework (NPPF) 2019 considers that small and medium-sized sites can make an important contribution to meeting an area's housing needs, particularly as they are often built-out relatively quickly. The London Plan 2021 highlights, under Policy H2: Small Sites, that boroughs should pro-actively support well-designed new homes on sites below 0.25 hectares in size in order to diversify the sources, locations, types and mix of housing supply. It also recommends boroughs to prepare housing design guidelines to support housing delivery on small sites. This policy is supported by the London Plan 2021 overarching principle of delivering Good Growth, whereby development should take a contextual approach in order to sustain and strengthen the character of the city's different neighbourhoods and growth should be directed towards the places with good accessibility to everyday needs, including town centres. Another key aspect of Good Growth is delivering the homes that London needs.

Small sites may often be challenging to develop due to constraints and complex surroundings. The Central Area Good Growth SPD provides guidance as to how

housing developments should be delivered on small sites in order to ensure that they are sympathetic to the surrounding context and that growth is achieved in a balanced and positive way.

Based on an updated character appraisal, the Central Area Good Growth SPD presents principles to accommodate growth and specific design guidelines for different types of small sites with the aim of supporting the achievement of Good Growth in the Central Area.

The SPD provides guidance on the implementation of the following policies from the Tower Hamlets Local Plan 2031:

- S.SG1:** Areas of growth and opportunity within Tower Hamlets
- S.SG2:** Delivering sustainable growth in Tower Hamlets
- S.DH1:** Delivering high quality design
- D.DH2:** Attractive streets, spaces and public realm
- S.DH3:** Heritage and the historic environment
- D.DH8:** Amenity
- S.H1:** Meeting housing needs
- D.H3:** Housing standards and quality
- S.OWS1:** Creating a network of open spaces
- D.OWS3:** Open space and green grid networks
- S.ES1:** Protecting and enhancing our environment
- D.ES2:** Air quality
- D.ES3:** Urban Greening and biodiversity
- D.ES5:** Sustainable drainage
- D.ES6:** Sustainable water and wastewater management
- D.ES7:** A zero carbon borough
- D.MW3:** Waste collection facilities in new development

1.3 How to use this SPD

**Status of the document**

The Central Area Good Growth SPD is a material consideration to help determine planning applications for small-scale residential-led developments in the central part of the London Borough of Tower Hamlets. The document supplements Tower Hamlets' Development Plan, which includes the Local Plan, London Plan and Neighbourhood Plans.

In addition to satisfying the requirements of national, regional and local planning policies, developments will also need to demonstrate how the guidance in this SPD has been taken into account. The document can also be used by anyone who is interested in understanding the role of design in ensuring that residential developments on small sites respect and enhance local character.

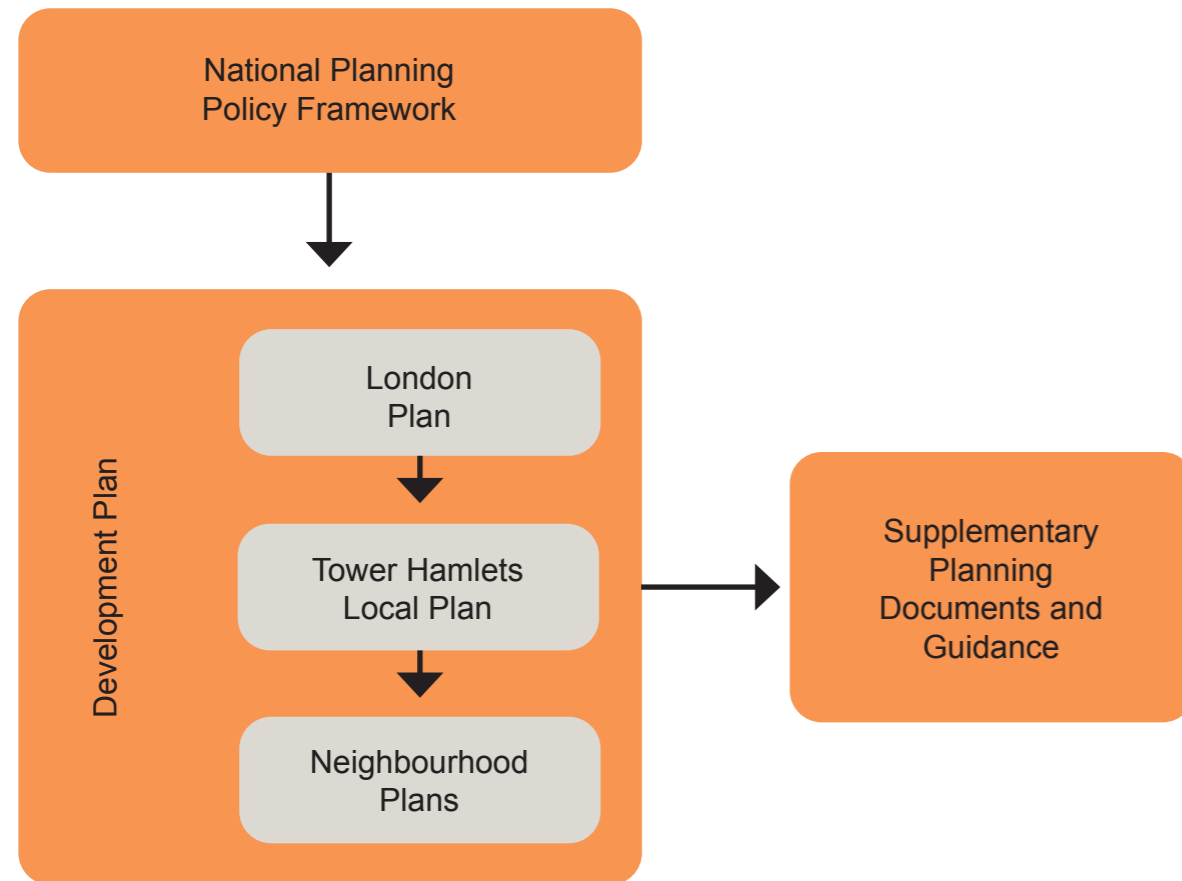

Figure 1: The Development Plan

1.3 How to use this SPD

**Where the guidelines apply**

The SPD is primarily a material consideration for residential-led developments on small sites located in the Central Area of the London Borough of Tower Hamlets (whose boundaries were defined by the Tower Hamlets Local Plan 2031), although it may also provide guidance that is applicable for residential developments on small sites located elsewhere in the borough. For the purposes of this SPD, small sites are defined as those of up to 0.25 hectares.

Developments may include roof/rear extensions to existing buildings and new build developments on sites of up to 0.25 hectares. The guidance applies to both extensions to existing dwellings as well as the creation of new dwellings. Developments may be as small as one residential unit and there is no defined upper limit, although it is expected that in most small sites this may be up to around 40 units. Although this SPD does not provide guidance on affordable housing provisions or developers' contributions, the guidelines contained here should be followed by all housing tenures. Major and minor developments will have different requirements relating to matters such as affordable housing and amenity space provisions (private, communal and play space) and applicants should refer to these in the Tower Hamlets Local Plan 2031 and Planning Obligations SPD 2021.

Some residential extensions and alterations may be covered by Permitted Development Rights (PDR). It is crucial to determine whether a proposal needs planning permission before undertaking any work. As developments that fall under PDRs are limited in what they can propose, applicants that wish to bring forward solutions that

fall outside of what is allowed under PDRs are encouraged to engage with this SPD to understand the principles that should be followed for developments to be deemed acceptable. For PDRs, it is also recommended that regard should be given to the principles provided by this SPD.

For developments within conservation areas applicants should also refer to the council's Conservation Area Character Appraisals and Management Plans. Any works to listed buildings are likely to require Listed Building consent in addition to any planning permission. Applicants should also refer to the Planning (Listed Buildings and Conservation Areas) Act 1990 and to the Tower Hamlets Archaeological Priority Areas Appraisal 2017.

This SPD does not cover tall buildings, nor does it provide guidance to policy D.DH6: Tall buildings from the Tower Hamlets Local Plan 2031. Tall buildings are classified as any building that is significantly taller than its local context and/or has a significant impact on the skyline. Within the borough, buildings of more than 30 metres, or those which are more than twice the height of surrounding buildings (whichever is less) will be considered to be a tall building. Applicants proposing tall buildings should refer to policy D.DH6, the High Density Living SPD and emerging Tall Buildings SPD.

**Structure of the document**

The SPD is divided in three parts: Introduction, Part A and Part B.

The introduction provides explanations on the application and use of the SPD, the policy context it relates to and background information on the production of the document.

Part A is a character appraisal of the Central Area. This presents a detailed analysis of each Character Place included in this part of the borough, as well as a study of the most commonly-found residential typologies. It builds on the Urban Structure and Characterisation Study (2009) and the Urban Structure and Characterisation Study – Addendum (2016) that form part of the Tower Hamlets Local Plan 2031 evidence base.

In addition to informing the guidelines contained in Part B, Part A should also be used by applicants to understand the character traits that developments need to respect and respond to.

Part B contains Guidelines for Good Growth. These are broken down into three levels of guidance: Character-based growth principles, which help to set out a context-led vision for sites at early design stages; Design toolkit for small sites, which presents site type-specific guidelines; and Design principles for residential developments, which contain guidelines that should be followed by all housing developments.

The diagram below summarises the contents of the SPD and how each part should be used.

**Chapter 1:** Understand how and where the SPD should be used.



Part A  
Character appraisal

Part B  
Guidelines for Good Growth

**Chapters 2 & 3:** Read about the Central Area and the Character Place(s) your site sits within and set out how the proposed development responds to context.

**Chapter 4:** Read about the typologies of buildings that your site is adjacent to and establish key characteristics that your proposed development should respond to.

**Chapter 5:** Set out a context-led vision for your site: Reinforcement, Mediation or Reinvention.

**Chapter 6:** Establish which site-type(s) is most applicable and read the appropriate design guidance.

**Chapter 7:** Read key design principles that residential developments should follow.

**Planning applications**

The document provides best-practice guidance on the implementation of existing policy and will be applied throughout the planning process.

• **Pre-application stage**  
Council officers will use this SPD to discuss how proposed developments are designed from early until late stage pre-application meetings. This includes ensuring that the growth vision for a site is appropriate for its surroundings (Chapter 5), that sites respond to context appropriately (Chapters 2-4) and that the design follows relevant guidance (Chapters 6 and 7). Due to the comprehensive approach of the document, not all design guidelines will be applicable for every scheme.

• **Application stage**  
As part of the planning decision-making process officers will take into consideration how the proposed development has considered the SPD when assessing the application against Tower Hamlets Local Plan policies.

**Intended users**

The document provides guidance on how to design residential developments on small sites in a way that they respect and enhance existing character. The document is intended to be used by various stakeholders and throughout the development process:

• The development community and designers to use in preparation of applications for residential-led developments on small sites. This may also include homeowners seeking to do extensions and groups interested in self-build and community-led housing.

• Council case-officers to use as a way to frame pre-application and application discussions.

• Council case-officers to review planning applications and assess if they meet the objectives of the Local Plan and result in high-quality developments that respect and enhance existing character.



## 1.4 How the SPD was developed

### How the SPD was developed

The Central Area Good Growth SPD was prepared under Regulations 11 to 16 of the Town and Country Planning (Local Planning) (England) Regulations 2012. The guidelines were developed in collaboration with residents, council services, Members, developers, architects, officers and experts in a range of fields. In order to prepare the SPD, we consulted with internal and external stakeholders. Findings from these exercises, along with best-practice case-studies from Tower Hamlets and wider London, are used to support each design recommendation. These were also supported by an analysis of existing policy and guidance and an extensive literature review on relevant topics for the SPD.

Early-stage engagement was conducted through a public online survey to gather ideas and initial feedback on the intended purposes of the SPD and on the Central Area's existing character. A series of workshops were also conducted with internal teams within the council and industry professionals. Early-stage feedback was incorporated into the draft that was presented for public consultation, which took place between January and February 2021.

Suggestions and recommendations received through email, the online survey and the events organised for the consultation period were carefully analysed and helped to inform the August 2021 version of the SPD. The document also presents anonymised quotes received from local residents in relation to each Character Place analysed in Part A.



## 1.5 Glossary

### Active frontages

A building front that promotes activity and encourages cross-movement between the building at ground level and the adjacent public realm by the way the building is designed or orientated. A building provides active frontage if the ground floor avoids blank walls or obscured frontages, includes windows and openings, and provides a variety of uses all of which also contribute to natural surveillance and support the visual and physical relationship between the building and ground level.

### Affordable housing

Social rented, affordable rented and intermediate housing provided to eligible households whose needs are not met by the market. Eligibility is determined with regard to local incomes and our (the council) housing allocation policy.

### Built edge

Edges are lateral points of reference on one's path that usually constitute a boundary between two or more areas such as roads, railway tracks and the border of a development. Edges might act as barriers, closing off one area from another and impeding or restricting movement, but on other occasions they might also connect areas by acting as seams. Generally, built edges act as barriers.

### Circulation space

Area of communal space from the main building entrance to the front door of a home. This covers the lobby, lift and corridor.

### Communal amenity space

An area within the curtilage of a residential development that can be accessed by residents of the development. It is used for recreation and provides visual amenity, e.g. gardens or landscaped space.

### Community facilities

Uses such as public houses, libraries, youth facilities, meeting places, places of worship, public conveniences and other uses in use class D1 that provide a service to the local community.

### Conservation area

An area of special architectural or historical interest, the character and appearance of which the council has a duty to preserve or enhance. The land, buildings and trees in these areas have special protection in the planning system.

### Daylight

Natural light that enters a building.

### Defensible space

A space between the public and private spheres that helps to provide security and privacy to homes.

### District centre

Centres that generally meet more local needs, with catchments of around 800 metres and provision of convenience goods and services. Typically, they contain around 10,000-50,000 square metres of retail, leisure and service floorspace, and often have specialist functions.

### Habitable rooms

A habitable room is defined as a room within a dwelling, the primary use of which is for living, sleeping or dining. This definition includes living rooms, dining rooms, bedrooms, studies, home offices and conservatories but excludes halls, corridors, bathrooms and lavatories. Kitchens which provide space for dining and have windows will be considered habitable rooms and should be included in the assessment of amenity impacts.



**LBTH**

London Borough of Tower Hamlets

**Legibility**

Legibility relates to how easily one can read, interpret, identify and remember places. It can also be thought of as the ease with which parts of the built environment can be recognised and organised into a coherent pattern. Legibility can be influenced by several elements such as streetscape, scale, pathways, among others. By being legible, a place usually enables users to move about easily and quickly, leading to spaces being perceived as more accessible and therefore being more actively used. It holds a close relationship with permeability.

**Listed building**

Buildings that are statutory listed and are classified into three grades, I, II\* and II. Listed buildings have their special architectural and historic interest protected by a special type of planning permission called Listed Building Consent.

**Maisonette**

A dwelling with more than one storey that is not a house, for example, a two-storey flat within a larger block.

**Major developments**

Developments with 10 to 100 residential units.

**Massing**

The combined effect of the arrangement, volume and shape of a building. It can also be referred to as bulk.

**Minor developments**

Developments with less than 10 residential units.

**Natural edge**

Natural edges are lateral points of reference on one's path that usually constitute a boundary between two or more areas such as canals, rivers or open spaces. Natural edges might act as barriers, closing off one area from another and impeding or restricting movement, but on other occasions they might also connect areas by acting as seams. Natural edges may be green or blue spaces.

**Neighbourhood centre**

Centres that contain clusters of retail and services to meet the needs of a more local catchment and typically contain at least sixteen units. Units are predominantly small-in-scale, with convenience supermarkets of around 500 square metres tending to be the largest occupants. Larger neighbourhood centres may also have particular specialist functions, and can be appropriate for some leisure and night-time economy uses.

**Open space**

All land that offers opportunity for play, recreation and sport or is of amenity value, whether in public or private ownership, and where public access is unrestricted, partially-restricted or restricted. This includes all open areas consisting of: major parks (e.g. Victoria Park and Mile End Park), local parks, gardens, squares, playgrounds, ecological spaces, housing amenity land, playing fields (including playing pitches), allotments and burial grounds, whether or not they are accessible to the public.

**Outlook**

Visual amenity enjoyed by occupants when looking out of their windows or from their garden.

**Permeability**

Permeability describes the extent to which urban forms permit (or restrict) movement of people or vehicles within, across and around an area. Permeability is normally considered a positive attribute as it encompasses ease of movement, avoids severing neighbourhoods and encourages active travel. It can also be referred to as connectivity and holds a close relationship to legibility.

**Permitted development rights**

Certain types of changes to a property without planning permission. The most common of these permitted development rights relate to extensions and alterations to dwelling houses, although they also apply to retail, industrial and other types of development. They also allow certain changes of use. Also commonly referred to as PDRs.

**Play space**

Spaces where play is identified as one of the prime functions. These include playgrounds, playing fields, skate parks and other recreation areas.

**Private amenity space**

An area within the curtilage of a dwelling that can be accessed by its residents. It is used for recreation and provides visual amenity, e.g. gardens, landscaped space, balconies, winter gardens.

**Public realm**

The space between and surrounding buildings and open spaces that are accessible to the public and include streets, pedestrianised areas, squares and river frontages.

**Scale**

The impression of a building when seen in relation to its surroundings and/or as experienced in relation to the size of a person (human scale). Sometimes it is the total dimensions of a building which give it its sense of scale, at other times it is the size of the elements and the way they combine.

**Setting of a heritage asset**

The surroundings in which a heritage asset is experienced. Their extent is not fixed and may change as the asset and its surroundings evolve. Elements of a setting may make a positive or negative contribution to the significance of an asset, they may affect the ability to appreciate that significance or they may be neutral.

**Small site**

Sites below 0.25 hectares in size.

**Street pattern**

The pattern of the arrangement and size of buildings and their plots, as well as the layout of streets and blocks in an area. When discussing street pattern, it is generally observed to which degree an area's pattern of street blocks and street junctions is respectively small and frequent, large and infrequent, or irregular.

**Streetscape**

The overall appearance of street elements that make up the street scenery and may include built elements as well as landscaping. The appearance of the streetscape is influenced by the quality of buildings, amenity spaces, sidewalks and greenery.

**Sunlight**

Direct, non-obstructed, sunshine.

**Sustainable urban drainage**

Water management practices that integrate natural water processes. Also commonly referred to as Sustainable Drainage Systems or SuDS.

**Typology**

Grouping buildings based on their form, architectural style, historical period, density, block layout and plot size. For example, a terrace, linear block or mansion block.

**Underground refuse stores /  
Underground waste collection**

Underground waste tanks with smaller access points integrated into the public realm. These are emptied on a regular basis by specialised collection vehicles. Underground refuse stores can also be referred to as URS.

**Urban greening**

Urban greening describes the act of adding green infrastructure elements such as green roofs, green walls, street trees, rain gardens and additional vegetation. The Urban Greening Factor is a land-use planning tool to help determine the amount of greening required in new developments.

**Water space**

All bodies of water, including canals, basins and the River Thames.

This page is intentionally left blank

# Part A Character appraisal

## 2. Overview

2.1 The Central Area: Setting the scene

The Central Area – whose boundaries are shown in the map in the following page, and were defined by the Tower Hamlets Local Plan 2031 – sits in the heart of the borough. It is primarily a low-rise residential area with shops and markets distributed across different neighbourhoods where they provide important meeting points for the local community.

The area contains several heritage assets and open spaces that are widely recognised such as Mile End Park and Victoria Park, as well as several canals and water spaces and a strong relationship with the River Thames.

The historical timeline in the following pages provides a summary of the development of this part of Tower Hamlets and also highlights some borough-wide significant events.



2.1 The Central Area: Setting the scene



The Central Area: Timeline

This timeline highlights key events that shaped the urban morphology of the Central Area of Tower Hamlets. For a detailed historic narrative, refer to the Tower Hamlets Conservation Strategy 2027.

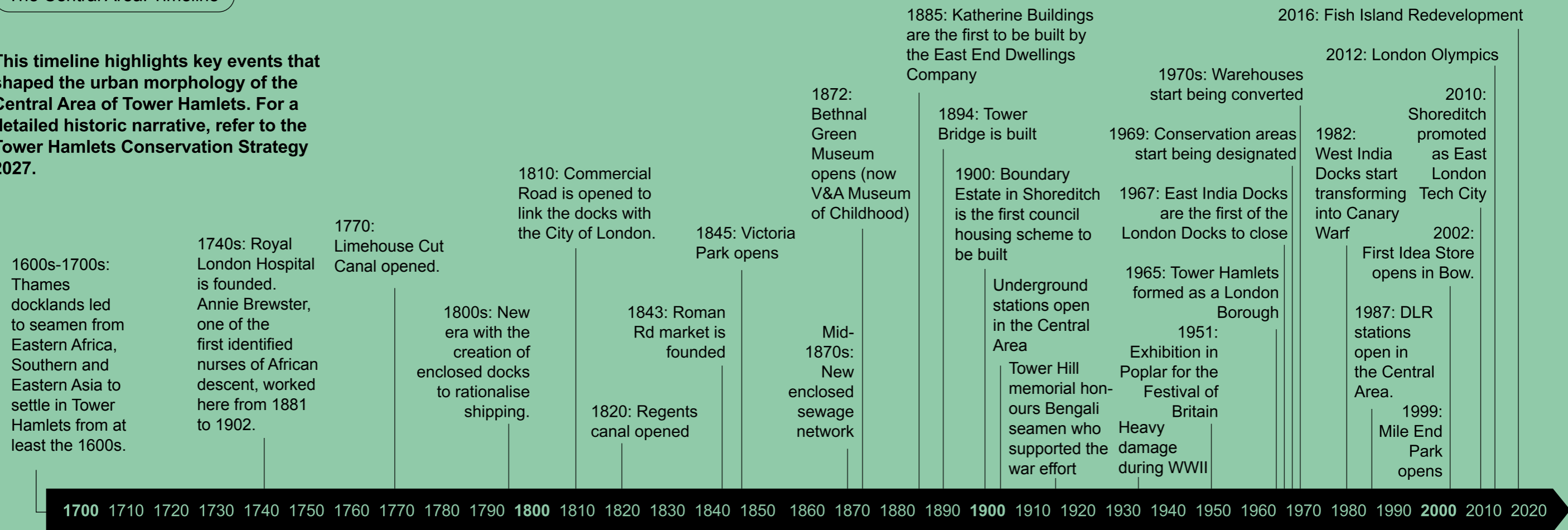

Mostly farmland with several settlements of various sizes as some areas became attractive for merchants and mariners, the silk weaving industry and other crafts.

Rapid growth in the whole of the Central Area culminating in overcrowding and poor living conditions.

Prosperity declined as the down-river docks grew in importance.

Post-war reconstruction, slum clearance & de-intensification.

New growth in Tower Hamlets with conservation, new-build and reconstruction projects.

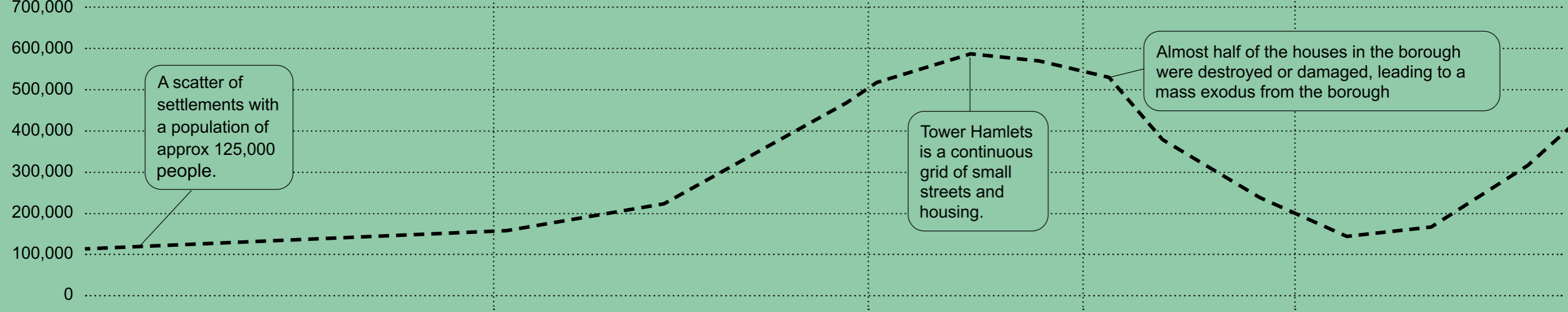

--- Tower Hamlets Population

# 3. Central Area Character Places

### 3.1 Introduction

The Central Area comprises ten Character Places (as defined by the Tower Hamlets Local Plan 2031 and highlighted in the map in the following page). Each of these has its own special character. As per the Local Plan, some of the Character Places only fall partially within the sub-area. It should be noted that the wards in the borough have their own boundaries which may not always align with the Character Places. The boundaries of each Character Place are also not strictly fixed as often there will be streets that fall under a transition zone. Applicants are encouraged to study not only the Character Place within which their site is located, but also the adjoining ones for a comprehensive picture of the place.

In terms of its history and how it is reflected in the built environment, the Central Area, much like Tower Hamlets and the East End in general, has experienced intense influx of migrant communities: 'The East End has experienced the near-continuous formation and re-formation of its built environment, shaped by the occupation and adaptation of existing buildings by migrant communities. The British Empire was dependent on continuous traffic between its colonies and the mother country, and the East End held strategic importance in these exchanges.'<sup>1</sup> The following pages describe key elements of local character for each of the ten Character Places of the Central Area whilst also reflecting on their special history.

The analysis addresses the topics of History; Heritage; Townscape; Street pattern and movement. The character appraisal builds on the previous borough-wide studies conducted by the council, namely the Urban Structure and Characterisation Study (2009) and Urban Structure and Characterisation Study – Addendum (2016), and adds a particular emphasis on typologies, by identifying the most typical

building types, in particular residential ones, in each Character Place, and by providing a detailed analysis of these in Chapter 4 - Central Area housing typologies.

1. Sarah A. Milne (2020) 'Accounting for the hostel for "coloured colonial seamen" in London's East End', 1942–1949', *National Identities*, 22:4, 395-42

### 3.1 Introduction



..... Central Area boundary  
■ Open space  
■ Water space

*Map showing the 10 Character Places that fall entirely or partially within the Central Area.*





**Introduction**

Bow is a predominantly residential area. Roman Road acts as an important hub for the community with its variety of shops, restaurants and cafés. In certain days of the week, there is a pedestrianised market on the east end of Roman Road selling a variety of food, clothing, crafts and books and attracting a high level of pedestrian activity.

- ..... Central Area boundary
- Open space
- Water space
- District centre

*'The energy of the community is made special from the buzz of activity. Roman Road's shops, multiculturalism and activity make the area retain a unique character that is rooted in excitement and positive change. History in Bow is visible and places of religious worship make the neighbourhood special. St Paul's Old Ford Road Church is, for me, a standout architectural heritage feature.'* (local resident)



**History**

The hamlet of Bow dates back almost a thousand years. By Tudor times, Bow was a thriving village. Up to the 1800s the small hamlet of Bow was surrounded by cornfields, pastures and meadows. The 19th Century however brought a massive increase in its population, and the construction of a number of significant factories producing rubber, soap and matches. The Bryant and May Factory was the scene of the famous Match Girls Strike of 1888. Bow was also the centre of the Women's Suffrage Movement. Roman Road Market was founded in 1843 as a general market for the poverty-stricken newcomers in the middle of last century. The market always thrived on its reputation for offering a huge variety of goods at keen prices. In its 1960s heyday, it was one of the most fashionable and popular markets in London. In the 1940s-1990s, slum clearance and

war damage resulted in the construction of post-war estates and the creation of Mile End Park on land devastated by bombing. The successive waves of migration to the area are illustrated by the re-use of religious buildings over time. At 43 Harley Grove, a Grade II listed chapel dating from 1855 became the Mile End and Bow Great Synagogue in 1927 and, from 1979, it has been in use as a temple known as the Gurdwara Sikh Sangat.

- ..... Central Area boundary
- Open space
- Water space
- ▨ Conservation area
- Listed building

**Heritage**

Approximately half of Bow sits within conservation areas. The western side includes four conservation areas characterised by the homogeneous layout of streets with mid- and late-19th Century 2-storey terraces: Driffield Road, Medway, Tredegar Square and Clinton Road Conservation Areas. Roman Road Market Conservation Area, on the eastern side of Bow, has more of a commercial character with small retail shops and modest houses enclosing them, but the streetscape maintains a domestic feel. Victoria Park and Regent's Canal conservation areas mark the north and west of Bow. They contain a mix of 19th Century terraces, post-war and early and late 20th Century buildings. Fairfield Road Conservation Area, further east, falls outside of the Central Area and it is dominated by the Grade II listed Bryant and May Match Works Factory, currently a gated residential development. Other listed buildings in the area include the Grade II Passmore Edwards Public Library and Church of St Paul with St Stephen.



*The Grade II listed former Bryant and May Factory, now a residential development.*

**Townscape**

Bow is predominantly a residential area, with the exception of Roman Road, where a mixture of uses animates the area, acting as a central point for the community. Roman Road consists of 2-3-storey buildings with small shops on the ground floor and residences above. The rest of the area is comprised mainly by residential typologies, varying in age and density. From post-war estates and 21st Century buildings west of Mile End Park, Bow transitions into a consistent 19th Century Victorian and later Georgian 2-3-storeys terraced housing area east of the park, particularly on side streets off Roman Road, in and around Medway Road and around Tredegar Square. Although there is no visible spatial barrier, there is a clear split between this part of Bow and the eastern side, where post-war estates of different kinds, from 22-storey towers to 3-4-storey deck-access blocks, are the predominant features of the townscape. Several estates are a result of clearance programmes or bomb-damaged terraces. Close to Victoria Park, facing Hertford Union Canal, there are former 20th Century industrial buildings converted into residential and mixed uses.

The largest green space in Bow is the northern part of Mile End Park. To the west of Regent's Canal, Meath Gardens also forms part of Bow's green spaces. Alongside Victoria Park, they provide good access to open space to the north and west of the neighbourhood. In contrast, a large proportion to the south-west has an open space deficiency.

Typical building types



**A.** The former Victoria Veneer Mills, from late 19th Century, of brick and with a pitched roof. The industrial building, located in the Regent's Canal Conservation Area, was converted into a mixed-use development.



**B.** Beatrice Webb House, a post-war housing block built in 1953 on the corner of a bomb-damaged terrace, within the Driffield Road Conservation Area.



**C.** The post-war Ranwell Estate, built in an area cleared from its 19th Century housing from the 1960s. It includes blocks and maisonettes of 2-3 storeys and three 22-storey towers built in 1969.

Typical building types



**D.** Terrace of 3-storey houses on Annie Besant Close from the 1960s. The terrace on the other side of the road is primarily 2-storey and white. All houses have single pitched roofs and façades with varying colours and brick detailing.



**E.** Roman Road Market with shops on ground floor and residences above, within the Roman Road Market Conservation Area. Buildings are 2-4 storeys and usually of brick.



**F.** The post-war Lanfrac Estate, built as a result of clearance programmes. The estate is a uniform collection of blocks with up to 4 storeys. Some variation is added by the differing tone of the brick and the varying design of the plans.



**G.** Victorian terraces built in the 1870s on Arbery Road within the Medway Conservation Area. The terraces display typical embellishments of the period, including bay windows and painted stucco decoration. On Arbery Road, in particular, they are ornately decorated.



**H.** The Suttons Wharf residential development completed in 2014 facing Regent's Canal and Mile End Park, with over 400 units and heights up to 17 storeys.



This page is intentionally left blank

**Street pattern and movement**

Bow generally has smaller, regular streets to the west and more irregular and complex street patterns to the east. There is poorer permeability and legibility in and around post-war estates and more recent developments, and easier movement where Victorian and Georgian terraces are prevalent. Roman Road narrows as it moves east through Bow, becoming a pedestrianised street market in its final stretch some days of the week. Bow has three key built and natural edges. The railway line to the south is a built edge that creates a spatial barrier. Mile End Park provides access to open space and constitutes a natural edge. Regent's Canal's narrow footpath to the west is well used by pedestrians and cyclists. Hertford Union Canal to the north suffers from a lack of publicly-accessible pathways on the Bow side. Roman Road and Old Ford Road are

key east-west links between Bethnal Green and Bow. Grove Road is a key north-south link. Parnell Road is a more local north-south link. These key links usually have high levels of traffic and carry vehicles from outside London. Bow has good transport links with Mile End and Bow Road underground stations nearby

- ..... Central Area boundary
- Open space
- Water space
- - - Natural edge (green space)
- - - Natural edge (blue space)
- //// Built edge
- ↔ Key vehicular link (A or B road)
- - - Cycling route



**Introduction**

Bow Common is predominantly residential, with some shops scattered around the area and few industrial uses around Limehouse Cut. Bow Common's post-war heritage is made apparent by the number of council estates built in that period.

- ..... Central Area boundary
- Open space
- Water space
- Neighbourhood centre

*'The canals and markets and the proximity to central London and Essex are what make this neighbourhood special'. (local resident)*

*'The many industries that occupy the railway arches are a key part of the local heritage'. (local resident)*



**History**

Bow Common was, for much of its history, a large area of marshland and meadows, which separated the hamlets of Poplar, Bromley and Bow. Lanes ran through connecting up these Hamlets and a number of small cottages and houses sprang up along these trade routes. These routes still exist today as Bow Common Lane and Devons Road/St Paul’s Way. The industrial revolution brought change to Bow Common, and with Limehouse Cut running through its southern edge, industries began to settle during the 19th Century. The growth and spread of Poplar and Bromley during this period led to the area becoming urbanised and swallowed up by its neighbours, hungry for space to expand. Between the 1920s and the 1940s, a resident of Turners Road was Chris Braithwaite. Originally from the Caribbean he enrolled as a colonial seafarer in the British merchant navy. After

... serving in WWI he settled in Bow and founded the Colonial Seamen’s Association, bringing together black and Asian seafarers in one organisation. Braithwaite tirelessly campaigned against inequality and injustice, both domestic and foreign, and wrote extensively on the travails of his seafaring comrades.

- ..... Central Area boundary
- Open space
- Water space
- ▨ Conservation area
- Listed building

**Heritage**

A small proportion of Bow Common is located within conservation areas. The whole of Swaton Road and Brickfield Gardens conservation areas are in Bow Common, as well as part of Limehouse Cut Conservation Area. Swaton Road Conservation Area covers a small fragment of low-rise terraces that were built for working-class Victorian families in the late 1860s and once covered this area. Brickfield Gardens Conservation Area also comprises fragments of the former Victorian streetscape, as well as two open spaces: Brickfield gardens, which used to be an area where bricks were made, as its name suggests, was an area created from cleared land after the war. Bow Common has a very small proportion of listed buildings, the most notable are the Grade II\* listed St Paul’s Church and The Widow’s Son Pub, on either side of Bow Common.



*Former stock brick Factory from 1911, within the Brickfield Gardens Conservation Area.*

**Townscape**

Bow Common’s land use is largely residential. The housing stock in the area predominantly consists of low-, medium- and high-rise post-war housing estates and more recent regeneration schemes. Much of the post-war estates are part of the Lincoln Estate which covered 1,495 acres when completed and includes two 19-storey towers of maisonettes, which were the tallest in East London when built. Other estates vary in design, massing and height and are distinguishable one from another. Several new housing developments have been built in the 2010s, mostly on previous industrial sites, others as redevelopments of post-war estates. A couple of industrial uses remain along Limehouse Cut, which is now predominantly residential. Although the area was predominantly covered with terraced housing before WWII, only a few fragments of terraces remain, most of which are now located in conservation areas.

Bow Common encompasses several neighbourhood parks, which are characterised by their small size. The nearby Tower Hamlets Cemetery and Mile End Park provide access to larger open space to the north and west of the neighbourhood. The south-eastern areas have an open space deficiency.

Typical building types



**A.** Completed in 2018, this 7-storey regeneration development forming part of the Burdett Estate includes a mosque and a school with residential units above.



**B.** Late 1860s 2-storey terraces with canted bay window at ground floor and simple Victorian sash windows above, stuccoed details on ground floor, part of Swaton Road Conservation area.



**C.** 4-storey uniform maisonette blocks, part of the post-war Lincoln Estate, built between 1958-1970s with over 800 dwellings. The estate also includes two 19-storey blocks. Much of the estate was refurbished in the 1990s.

Typical building types



**D.** 5-storey brick housing blocks from 1929 with a Neo-Georgian façade to the front and utilitarian deck-access at the back.



**E.** Housing development with varying heights, up to 14 storeys, facing Limehouse Cut completed in the late 2010s to replace a former industrial use of the site.



**F.** Early post-war blocks of 4-6 storeys with a regular grid and projecting balconies. Pitched roofs and other features were added between 1998-2000.



**G.** Late 19th Century grand terraces with elevated ground floor, semi-basements, 3-sided bay windows and decorative stuccoes surrounds to windows and doors, remnants of the Cotton Estate, now part of the Brickfield Conservation Area



**H.** 3-storey post-war housing blocks built between 1957-1958 with plain brick panels, recessed private balconies and shallow gabled roofs.



This page is intentionally left blank

**Street pattern and movement**

Apart from key links, Bow Common mostly has an irregular street pattern with large urban blocks due to historic industrial uses and the high number of post-war estates. The estates' layout, including cul-de-sacs and disorientating street pattern, is a barrier to movement in the area and has a negative effect on legibility. There is also a degree of detachment in Bow Common. This is caused by Limehouse Cut to the south, the railway lines to the north, and Burdett Road to the west. The latter is classified as a highway and is a key north-south link in Tower Hamlets. The towpath on the south side of the canal is used by pedestrians and cyclists as a key east-west link towards Limehouse. Limehouse Cut, however, has a limited number of crossing points. Bow Common has no stations, although it lies in close proximity to Devons Road and Limehouse DLR stations.

- ..... Central Area boundary
- Open space
- Water space
- - - Natural edge (blue space)
- ////// Built edge
- ↔ Key vehicular link (A or B road)
- - - Cycling route





**Introduction**

Globe Town is predominantly a residential area. The town centres along Roman Road and Cambridge Heath Road include shops, restaurants, markets, green grocers and local services and they animate the area. The western part of Globe Town has important institutional buildings such as the V&A Museum of Childhood. The northern part includes creative industries and to the south there is the Tramshed Community Hub which is a focal point for the community.

- ..... Central Area boundary
- Open space
- Water space
- Neighbourhood centre
- District centre

*'The northern and eastern edges of Globe Town are very influenced by Victoria and Mile End parks which border them. For instance the Park View Estate was designed and named for its proximity to Victoria Park'. (local Resident)*



**History**

Globe Town was established in 1800 to provide for the expanding population of weavers around Bethnal Green. Since the 1820s the area is known by Globe Town. Bethnal Green's population trebled between 1801-1831. By 1824, with restrictions on the importation of French silks relaxed, several looms became idle, and prices were driven down. The abundance of cheap labour was turned to furniture, clothing and shoe manufacture. Globe Town continued its expansion into the 1860s, long after the decline of the silk industry. When slum clearances increased towards 1900, initiatives to provide working-class housing were explored. This was attempted by Samuel Barnett's East End Dwellings Company with the red brick tenements around Globe Road in the 1880s. Most of this development was built by this company between 1900-1906. Providing a place

of worship for Asian communities, the Grade II listed Shahporan Mosque at 444 Hackney Road illustrates how the earliest mosques in the area were formed through the conversion of houses. The recent addition of an Islamic Centre to the mosque demonstrates how traditional Islamic art can be abstracted to create a bold façade, creating a dialogue between new and old and enriching the streetscape.

- ..... Central Area boundary
- Open space
- Water space
- ▨ Conservation area
- Listed building

**Heritage**

Approximately half of Globe Town sits within conservation areas. In the Victoria Park and Regent's Canal conservation areas, many of the historic industrial buildings, bridges and locks associated with the canals make a significant contribution to the townscape. The 19th Century terraces, some of them Grade II listed, contribute to a coherent and distinctive character in the area and pockets of post-war development are found where terraces have been lost and redeveloped. The Bethnal Green Gardens Conservation Area is characterised by public and civic uses, including the Grade I listed Church of St John on Bethnal Green and the Grade II\* V&A Museum of Childhood, in contrast with the residential character found in the generally homogeneous group of late Victorian dwellings that make up Globe Road Conservation Area. To the south, the character of St Peter's conservation area is defined by 19th Century residential terraces and the former church of St Peter's, listed at Grade II. Carlton Square has a cohesive group of Victorian housing, which remain largely intact despite war damage. Only a very small part of Hackney Road Conservation Area falls within Globe Town.



*The Grade II\* listed V&A Museum of Childhood, within the Bethnal Green Gardens Conservation Area.*

**Townscape**

Globe Town is predominantly a residential area, with the exception of the buildings with institutional purposes such as the Bethnal Green Police Station and the V&A Museum of Childhood to the west, the creative industries to the north close to Regent's Canal, and the mixed uses along Roman Road, which create a hub of activity right in the middle of Globe Town, in and around Globe Town Market. This key east-west link has small retail units on the ground floor with residential units above. The rest of Globe Town is comprised by residential typologies that vary in age and density. There are several post-war housing estates, early and late 20th Century housing blocks and a smaller proportion of early to late-19th Century Georgian and Victorian terraces. The terraces bring a smaller scale and height in contrast to the medium to high-rise estates and housing blocks.

The largest park within Globe Town is Bethnal Green Gardens, located to the west. Apart from a series of small open spaces, the neighbourhood also has easy access to Mile End Park and Victoria Park to the east and north, and to Meath Gardens, to the east. There is some open space deficiency to the north and centre of Globe Town.

Typical building types



**A.** A late 20th Century residential development of brick and 2-3 storeys which includes sheltered, rental and shared ownership accommodation.



**B.** Mulberry House, completed in 1936 as part of a slum clearance programme. Part of the Bethnal Green Gardens Conservation Area, the building is Neo-Georgian with 3-storey canted bay windows and brick.



**C.** Victorian terraces on Approach Road, within the Victoria Park Conservation Area, with stock brick and windows with moulded architraves. Most houses were built in the 1860s, by multiple builders.

Typical building types



**D.** The post-war Park View Estate, from 1953, designed so as to allow views to Regent's Canal and Victoria Park. Within the Victoria Park Conservation Area, it is of brick with cantilevered balconies.



**E.** The post-war Cranbrook Estate on Roman Road completed in 1968. The 'X' layout of wide pedestrian avenues were designed to echo the pattern of 19th Century streets to the north.



**F.** 21st Century gated residential development with blocks with heights increasing from 4 to 9 storeys as the scheme approaches Regent's Canal.



**G.** Mixed-uses characteristic of high streets, with shops on the ground floor and residences above, as seen on Roman Road. Heights vary from 2 to 4 storeys.



**H.** The post-war Bancroft Estate, completed in 1954. The estate displays a mix of balcony-access flats refurbished in the 1990s (seen in the picture), as well as low-rise cottages and houses.



This page is intentionally left blank

**Street pattern and movement**

The large proportion of 20th Century estates and housing blocks translates into an irregular street pattern with large plots, compromising permeability and legibility in the area. There are pockets of smaller streets and regular street pattern where Georgian and Victorian terraces are found. Globe Town has two key edges: the railway line to the south, and Regent's Canal. The former constitutes a spatial barrier with few active frontages in the archways, effectively cutting off the southern part of Globe Town. Regent's Canal is largely inaccessible due to pathways falling within private backgardens or a lack of pathways entirely. Roman Road and Old Ford Road are key east-west links between Bethnal Green and Bow. Bishops Way/Sewardstone Road is a local east-west link. Cambridge Heath and Globe Road are key north-south links. Globe Town has excellent transport

links with easy access to Bethnal Green Underground Station and Cambridge Heath Overground Station.

- ..... Central Area boundary
- Open space
- Water space
- - - Natural edge (blue space)
- //// Built edge
- ↔ Key vehicular link (A or B road)
- - - Cycling route



### Introduction

Limehouse is a riverside neighbourhood. It is predominantly a residential area interspersed with offices, shops, hotels and some institutional and creative uses. Limehouse's industrial heritage is made apparent by the remaining warehouses, now converted into offices, studios and flats. The Limehouse Basin, now used as a marina, is the focal point of the neighbourhood.

- ..... Central Area boundary
- Open space
- Water space
- Neighbourhood centre

*'Appreciation and respect for the historic environment, whether that is through its architecture or landmarks, is key to Limehouse. Contemporary change is good when it respects this. It is all part of the process of evolution: old and new – they are not different things, it is all one.'* (local resident)



**History**

Limehouse is named after the lime coasts or kilns that were established there in the 14th Century and used to produce quick lime for building mortar. In the days of the docks, the area was associated with imports. This is in contrast to the preceding years when it was associated with exporting beer and voluntary and involuntary emigrants. Together with nearby Poplar, Limehouse was also the setting of London's original Chinatown, with Limehouse Causeway, Pennyfields and West India Dock Road at its heart in the 1890s. In the 19th Century the canal system originating in Tower Hamlets was the entrance to the busy arterial route serving Britain's commercial life. The Limehouse Cut has only been connected to Limehouse Basin since being re-routed in the 1960s. As London expanded rapidly in the early 19th Century, Commercial Road was opened in 1810 to link the emerging docks with the City of London. The Empire Memorial Hostel, on the corner of Commercial Road

and Salmon Lane, was opened in 1924, funded by the Ladies Guild of the British Sailor Society. It provided a place to stay for seamen without accommodation until their next assignment. Men from all over the British Empire, including many black sailors, stayed here until it closed in 1979. It has since been converted into flats.

- ..... Central Area boundary
- Open space
- Water space
- ▨ Conservation area
- Listed building

**Heritage**

Approximately half of Limehouse sits within conservation areas. To the west, the small stretch of York Square Conservation Area within Limehouse includes large-scale buildings with commercial and institutional purposes. Albert Gardens Conservation Area comprises an open space enclosed by Grade II listed Victorian terraces from the 1840s, whereas the small stretch of the Wapping Wall Conservation Area included in Limehouse is characterised by converted warehouses. Lowell Street includes early 19th Century Grade II listed terraced housing on Commercial Road. Within the St Anne's Church Conservation Area, the Grade I listed church and other public buildings from the 18th Century and more recent residential developments make up the townscape. Narrow Street Conservation Area is characterised by 19th and 20th Century wharf-side buildings relating to the port and commercial activities which developed following the opening of Regent's Dock (now Limehouse Basin) in the early 19th Century. Only a very small part of Limehouse Cut and Regent's Canal conservation areas fall within Limehouse.



*The Grade I listed St Anne's Church from 1730.*

**Townscape**

Limehouse is largely a residential area with the exception of the mixed uses along Commercial Road and the institutional buildings around St Anne's Church to the east. The main typology found are 19th Century former industrial warehouses converted into residential, creative and office uses in the 1950s. The area has also seen brand-new high-end residential buildings from late 20th Century and early 21st Century, including high-rise towers and blocks with 5-6 storeys. Some of the riverside developments are gated and the access to the River Thames has been blocked in many instances. Limehouse also includes some post-war council estates, concentrated in the south-west and north of Limehouse, with blocks ranging from 2-storeys high to 8-storeys high. Despite the varying typologies, there is a consistent feel to the area's townscape thanks to its industrial heritage and overall consistency of materials, including in the more recent developments.

Limehouse includes substantial water space with the River Thames, Limehouse Basin and the Limehouse Cut and Regent's Canal. The neighbourhood encompasses several small neighbourhood parks including Ropemakers Field and King Edward Memorial Park, but a significant proportion to the west of Limehouse Basin has an open space deficiency with a lack of green spaces.

Typical building types



**A.** The post-war Glamis Estate (East), one of the last major estates built by the Greater London Council in the 1970s. It displays a concern for a more human scale with blocks of pale brick with up to 8 storeys. One terrace includes projecting glazed stair walls.



**B.** Victorian terraces built in the 1840s, within the Albert Gardens Conservation Area. They are of 3 storeys and basements, and have recessed sashes with glazing bars, those of ground floor with semi-circular heads in double recesses.



**C.** Post-war 3-storey blocks of flats with balconies extending over shops, built in 1958 on Salmon Lane as part of the Locksley Estate.

Typical building types



**D.** The former Limehouse Town Hall, built in 1881 on Commercial Road, within the St Annes' Church Conservation Area, and converted into a cultural hub. It is of brick with stone dressings and listed at Grade II.



**E.** Residential towers completed in 1998 as part of Basin Approach, a residential development around Limehouse Basin. The four blocks are of 8 storeys with the upper one of double-height. It is of brick with projecting balconies onto the basin.



**F.** Cluster blocks built in 1986 in Goodhart Place, next to Limehouse Basin, with 3-4 storeys, yellow brick and projecting balconies.



**G.** 19th and 20th Century warehouses on 22-28 Narrow Street, within the Narrow Street Conservation Area, among the first to be converted into residences in the Docklands in the 1970s. They have façades with varying brick types. Heights are of 4-6 storeys.



**H.** Free Trade Wharf built in 1796 on the Thames Path, within the Wapping Wall Conservation Area. The warehouses were converted into offices and residences in 1987. It is of yellow brick, 9 bays with a 10th bay expressed as a pedimented 2-storey pavilion.



This page is intentionally left blank

**Street pattern and movement**

Limehouse has a juxtaposition of small and regular streets with larger roads with large urban blocks, which compromises the legibility and permeability of the area. Narrow Street is an example of an enclosed road that nevertheless provides a legible route; the presence of large blocks on the riverfront, combined with a lack of publicly-accessible pathways, often makes it difficult, however, to access the River Thames. The river, Limehouse Basin and Limehouse Cut act as natural edges. There are publicly-accessible pathways along Limehouse Basin and Cut. The railway line is a built edge that creates a spatial barrier between north and south. The Rotherhithe and Limehouse Link Tunnels are also built edges that act as spatial barriers. For a relatively small area, Limehouse is cut by several roads that connect it to the City of London and Canary Wharf, but that end up

affecting the area’s cohesion by creating pockets of development. Commercial Road, Cable Street and The Highway are key east-west links with high levels of traffic. Limehouse has excellent transport links, including Limehouse and Westferry DLR stations.

- ..... Central Area boundary
- Open space
- Water space
- - - Natural edge (blue space)
- //// Built edge
- ↔ Key vehicular link (A or B road)
- - - Cycling route





**Introduction**

While most of Mile End is residential, the town centre around Mile End Underground Station is a busy transport and social hub with concentrated commercial use on ground floor units in that area. The campus of Queen Mary University of London is located to the north-west of Mile End and numerous landmarks can be observed along Mile End/Bow Road.

- Open space
- Water space
- Neighbourhood centre

*'The parks and canals around here help it feel more open and provide easy access to nature. Which is really great considering how central it is. It is, however, a very busy residential area. Rush hour around Mile End is a nightmare, specially as the station is right next to a busy road.'* (local resident)



**History**

Mile End dates back to the 13th Century. It was named due to the distance along the road from London: one mile east from the City of London. Urbanisation began along this important trade route during the Georgian Era. The area's development continued to progress rapidly in the 18th Century when it became attractive for a wealthy new class of merchants and mariners. Trade and shipping shaped Mile End dramatically during this period. Development intensified in the 19th Century due to significant increases in London's population and UK economy. Mile End's expansion and importance during this period was reflected in a number of civic buildings, like the 'People's Palace' from 1887, which was destroyed in a fire and replaced in 1937. In the 1940s-1990s, slum clearance and war damage resulted in the construction of post-war estates and the creation of Mile End Park on land

devastated by bombing. On the corner of Alfred Street and Bow Road, a memorial clock and plaque on the building called Electric House, commemorates Minnie Lansbury, born nearby in 1889 to Jewish émigré parents. After becoming a teacher, suffragette and then elected councillor, she was jailed in 1921 along with five other women for refusing to charge full rates from her poorest constituents. The clock was erected by public subscription.

- Open space
- Water space
- Conservation area
- Listed building

**Heritage**

Approximately half of Mile End sits within conservation areas. Tredegar Square, Ropery Street and Tomlins Grove conservation areas include predominantly uniform groups of Victorian and Georgian terraced housing. The considerable unity and long views are an essential element of these conservation areas which include numerous listed buildings. The Tower Hamlets Cemetery Conservation Area is marked by the substantial institutional built heritage, including the site of former St-Clements Hospital, which has been since 2017 the site of London's first community land trust (CLT) housing project. Part of Regent's Canal and Clinton Road conservation areas are also included within Mile End. Most of Mile End's listed buildings are located within conservation areas and include a number of terraces, religious and institutional buildings. Dotted along Mile End/Bow Road several landmarks can be observed, such as the former People's New Palace which is now part of Queen Mary University of London, the former Coborn School for Girls (1897-1898) and Georgian terraces within the Tredegar Square Conservation Area.

**Townscape**

Mile End is essentially a residential area, with the exception of the mixed uses along Mile End/Bow Road and Queen Mary University of London. The commercial roads primarily consist of small-scale shops intermixed with housing, with shop uses intensifying near Mile End Underground Station. Around the station and under Mile End Green Bridge there are several restaurants and cafés, that create a hub of activity. The university also creates a busy hub. The housing varies in age and density, from low-rise Victorian terraces and low- and medium-rise Georgian townhouses, to medium- and high-rise post-war council estates. Both typologies are interlaced in clusters. The post-war estates (Ocean Estate, British Street, Eric&Tracey, Bede Estate) have replaced areas of former terraced housing after bomb-damage and slum clearance. Many of these have undergone redevelopment, refurbishments and intensifications since the 2000s.

The south of Mile End Park and Tower Hamlets Cemetery are located within Mile End, providing good access to open space to the entire neighbourhood.



*The Grade II listed former People's New Palace, from 1937.*

Typical building types



**A.** 9-storey student housing development on Mile End Road which opened in 2012 in the vicinity of Queen Mary University.



**B.** Georgian terrace within the Tredegar Square Conservation Area which was mainly developed between 1820-1860.



**C.** The post-war British Street Estate, developed between 1969-1976, contains 500 dwellings. It comprises two 22-storey tower blocks and numerous low-rise block of flats and maisonettes. It was recently refurbished.

Typical building types



**D.** Late 20th Century 4-storey cluster blocks with surrounding housing developments in the same architectural language.



**E.** Ropery Street Conservation Area terrace dating from mid- to late 19th Century. The uniformity differs street-by-street, with varying level of intricate detailing on the façades.



**F.** The post-war Bede Estate. The majority of the estate was built between 1964-1971 and comprises primarily 4-storey brick units made up of deck-access maisonettes.



**G.** Terrace with ground floor shops and varying window treatments on Burdett Road, within the Ropery Street Conservation Area.



**H.** The post-war Ocean North Estate. Primarily built in the 1950s and the 1960s, the estate presents a relatively homogeneous architectural language with deck-access units of 3-6 storeys and an area of terraces.



This page is intentionally left blank

**Street pattern and movement**

Mile End has a mix of regular and irregular street patterns throughout the area. A number of large blocks are found in and around the centre of Mile End, particularly post-war council estates and university buildings, which cause limited permeability. Some areas contain small blocks and a historic street pattern, such as around Tredegar Square, which eases movement. Mile End Road/Bow Road runs east-west through Mile End and is primarily a through route for traffic from London to Essex, though it also carries local traffic. The road forms a significant barrier to north-south pedestrian movement, along with Burdett Road which forms a barrier between residential areas and Mile End Park. These key links usually have high levels of traffic. To the south and east, the railway line is a built edge. The park, as well as Regent's Canal constitute natural edges. Mile End has excellent transport links with both Mile End and Bow Road underground stations.

- Open space
- Water space
- Natural edge (green space)
- Natural edge (blue space)
- Built edge
- Key vehicular link (A or B road)
- Cycling route



**Introduction**

Poplar is a predominately residential area with concentrated commercial use in and around Chrisp Street Market, a local hub of activity for the community. Poplar High Street, which falls outside of the Central Area, is another commercial hub within which Tower Hamlets College is based.

- ..... Central Area boundary
- Open space
- Water space
- Neighbourhood centre
- District centre

*'Poplar's best features are good quality post-war social housing, Chrisp Street market and good parks.'* (local resident)



**History**

In the mid-17th Century there were just a double row of houses along Poplar High Street. Merchants and shipbuilders preferred to live further North or in more rural areas between the 17th-18th centuries. As the population began to grow rapidly after the construction of the East India Docks at the start of the 19th Century, the East India Dock Road was built, between 1806-1812, to improve communication between the area's maritime industry and the City. Much of the mid-19th Century growth had taken place north of East India Dock Road, where Poplar New Town was built up with modest terrace housing between 1830s-1860s. Prosperity declined in the area after 1880 as the down-river docks grew in importance and Poplar was heavily bombed during WWII. The dominance of public housing is a relatively recent phenomenon. Most of it was built between 1950-1980 as post-

war reconstruction schemes. Although the Chinese population moved out of the area after WWII to settle in London's current Chinatown district in Soho, its legacy can still be detected in some of Poplar's street names, such as Canton Street, Pekin Street and Nankin Street, established around the 1890s. The Chun Yee Society at 50 East India Dock Road began in circa 1906 as a sailors' shelter and a Sunday school and still operates today to advance education and provide facilities to the local Chinese community.

- ..... Central Area boundary
- Open space
- Water space
- ▨ Conservation area
- Listed building

**Heritage**

A large proportion of Poplar is located within the Lansbury Conservation Area. The latter is named after George Lansbury, a former local MP. It includes low-rise and medium-rise post-war housing, schools and churches, north of East India Dock Road. The first phase of Lansbury – which is now the outline of the conservation area – was part of the 1951 Festival of Britain, as an example of what might be achieved as Britain's cities were starting to be rebuilt after the war. A number of Grade II listed buildings are dotted around Poplar, mostly dating from the 1951 Festival. Others date from mid-late 19th Century, such as George Green Almshouses and St Saviour's Church, a reminder of the area's growth in that period.

**Townscape**

The daily market off Chrisp Street is a popular shopping destination for locals and, along with the Idea Store and other shops, creates a vibrant heart to the area. Chrisp Street Market is set off Chrisp Street and East India Dock Road, though it is largely unseen from either road. East India Dock Road contains a number of small shops with mixed uses above them. The residential buildings found in Poplar consist of largely low- and medium-rise post-war housing estates, interspersed with high-rise housing towers. The majority of the industrial buildings along Limehouse Cut have been redeveloped into modern housing or warehouse conversions and a number of the post-war estates have been redeveloped in recent years.



*The 1954 Roman Catholic Church of Saints Mary and Joseph in the Lansbury Estate.*

Bartlett Park, a district park located within Poplar, provides the main accessible open space to the neighbourhood.

Typical building types



**A.** Mixed-height linear blocks of up to 10 storeys built in the 2010s, with views facing towards Limehouse Cut.



**B.** Self-built row of houses built between 1987-1989 in pale brown-black brick and pitched/hipped roofs influenced by the materials of St. Saviours Church and its former vicarage, which the houses surround.



**C.** 2000s housing development of 2-3 storeys, folded linear blocks for mixed-tenure of approximately 118 units.

Typical building types



**D.** Three of eight 11-storey post-war council housing towers interspersed with 4-storey maisonette blocks built between 1957-1963.



**E.** Market place with shops on ground floor and maisonettes above built for the 1951 Festival of Britain.



**F.** Front-to-back arrangement of terraced houses built in 1982, with front doors facing footpath and car parking in the close behind.



**G.** Post-war 3-4 storey housing development with spines and wings of maisonettes from the 1970s, known as the Gough Grove scheme.



**H.** Mix of 3- and 6-storey blocks completed in 1951 and built with London stock brick and slate to reflect the existing housing stock of the area at the time, part of Lansbury Conservation Area.



**Street pattern and movement**

Chrip Street Market and the area around the Idea Store is a well-used, pedestrianised area. The majority of Poplar comprises post-war council estates which translate into an irregular street pattern with large blocks, compromising permeability and legibility in the area. Poplar is bounded by Burdett Road to the west, Limehouse Cut to the north, which acts as a natural edge, the DLR to the east, and East India Dock Road to the south. Both Burdett Road and East India Dock Road are high-traffic highways, and therefore create a barrier to Mile End Park. On the other hand, East India Dock Road is an important east-west link across Tower Hamlets from the City of London to Newham, and Burdett Road is an important north-south link from the south of Tower Hamlets and Canary Wharf to Hackney. Poplar has no stations, although it is located in close proximity to Langdon Park, Westferry and Poplar DLR stations.

- ..... Central Area boundary
- Open space
- Water space
- - - - Natural edge (blue space)
- //// Built edge
- <- - - -> Key vehicular link (A or B road)
- - - - Cycling route

This page is intentionally left blank





**Introduction**

Shadwell is a residential area interspersed with shops, restaurants and cafés. It includes Watney Market, a medium-sized open-air market, that is widely used by residents as a shopping destination. The stretch of Shadwell included in the Central Area is primarily a residential area with some institutional uses also present. Its main focal point is the Shadwell Basin, now used for recreation.

- ..... Central Area boundary
- Open space
- Water space
- District centre

*‘The proximity to the River Thames and the local green spaces, including allotments and pocket parks are what stands out in Shadwell. It also has excellent connectivity with the CS3 cycle network and great public transport links.’ (local resident)*



**History**

Shadwell literally means ‘the well of shadows’. It was a riverside settlement that developed rapidly in the 17th Century, through the expansion of shipbuilding and maritime industries. Throughout the 17th, 18th and 19th centuries the district accommodated an expansion of docks by the East India Company, the West India Company and other mercantile trading interests, creating an entry hub drawing migrant people into the area. Early settlement was largely destroyed in the 19th Century by the creation of Shadwell Basin. With increasing demand for both dockworkers and sailors, the area also lost its base of skilled artisans and professional families and became overcrowded. Later, philanthropic enterprises helped the overcrowded Jewish immigrants living in the area further north around Commercial Road. On Dock Street is a plaque commemorating the 1936 ‘Battle of Cable Street’ when groups of Jews, dockers of all

ethnic groups and ex-servicemen prevented the fascist followers of Sir Oswald Mosley from marching into the East End. After WWII this area was known as the ‘Harlem of London’ due to its concentration of black and minority residents, with cafés and lodging houses often run by former seamen. Radical post-war re-planning after extensive bomb damage disrupted old patterns. New housing was designed away from the old routes, while the historic centre of Shadwell in Shadwell Docks gravitated towards Watney Street Market in the north. Following the founding of Bangladesh in 1971, a large Bengali migration to the area led to the establishment of a British Bangladeshi community in the district.

- ..... Central Area boundary
- Open space
- Water space
- ▨ Conservation area
- Listed building

**Heritage**

The extent of Shadwell that falls within the Central Area includes the St Paul’s Shadwell Conservation Area and part of the Wapping Wall and Commercial Road conservation areas. St Paul’s Shadwell Conservation Area includes the Grade II\* listed church of the same name and its grounds, which form a dramatic backdrop to Shadwell Basin. The stretch of the Wapping Wall Conservation Area that falls within Shadwell mainly comprises converted warehouses and other industrial buildings such as the former Wapping Hydraulic Pumping Station, listed at Grade II\*, reminders of the industrial past of this area. It also includes Shadwell Basin. As the name suggests, the Commercial Road Conservation Area stretches around the road of the same name, opened in 1810 to link the emerging docks with the City of London. The prevailing 19th Century Victorian character of this area was mostly lost through post-war housing redevelopment. The remaining Victorian terraces form a homogeneous group. The stretch of the Commercial Road Conservation Area that falls within the Central Area in Shadwell includes the Grade II listed Church of St Mary and St Michael.



*The Grade II\* listed former Wapping Hydraulic Pumping Station from 1893, within the Wapping Wall Conservation Area.*

**Townscape**

The stretch of Shadwell included in the Central Area is largely a residential area with a variety of typologies and densities. Originally lined with warehouses, Shadwell Basin is now surrounded by a residential scheme with rows of houses with up to 3 storeys, built in 1987. South of Shadwell Basin and close to the River Thames, there is a mixture of converted 19th Century industrial buildings and brand-new residential buildings from the 1980s-1990s designed with a similar scale and materials to the original warehouses in the area. These present larger plots and 4-6 storeys. The area has also seen some piecemeal brand-new developments that do not make reference to the industrial past of the area. Shadwell also includes post-war council estates, particularly to the north of The Highway and Cable Street, with low, medium and high-rise blocks, as well as 2-3 storey rows of houses from early 21st Century.

Shadwell includes significant water space with the River Thames and Shadwell Basin. Within the Central Area, Shadwell has no significant open spaces besides the tree-lined path along the Basin and St Paul’s Shadwell churchyard. There is easy access to Wapping Woods and King Edward Memorial Park. The areas either side of Commercial Road have an open space deficiency.

Typical building types



**A.** Grade II listed residential development with houses of up to 3 storeys, built in 1988. The quayside colonnades make reference to the forms of 19th Century dock buildings. The buildings also displays arches with Venetian openings and split gables.



**B.** Student housing development for Goldsmiths University students on King David Lane built in 2009-2010, with up to 8 storeys and balconies for each floor.



**C.** The post-war Glamis Estate (West), one of the last major estates built by the Greater London Council in the 1970s. It comprises 2-3 storey blocks with deck-access and courtyards, and a 22-storey tower block.

Typical building types



**D.** Early 21st Century terrace of yellow and orange brick, 2-storey plus attic houses on Oyster Row, next to the railway track.



**E.** The Grade II listed St Paul's Terrace, a 1820 stepped 2-storey terrace of 1-bay houses built of stock brick, giving onto a courtyard below.



**F.** Prospect Wharf, a large-scale block of flats built in 1987 on the site of a former warehouse, within the Wapping Wall Conservation Area. 4-5 storeys-high with an elevated ground floor, it is of brick with a concave riverfront and irregular gables.



**G.** The Grade II listed Prospect of Whitby, a public house from circa 1520 with a 19th Century façade within the Wapping Wall Conservation Area. The building is a reminder of the narrow width of the 16th Century riverfront plot.



**H.** Prospect Place, a late 20th Century residential development within the Wapping Wall Conservation Area. The use of brick and the building's wide façades make reference to the area's industrial heritage.



This page is intentionally left blank

**Street pattern and movement**

Within the Central Area, Shadwell has mostly large urban blocks due to the predominance of former industrial buildings and post-war estates, affecting ease of movement and legibility. This is improved in the areas of smaller plots and regular street pattern, particularly in the residential developments surrounding Shadwell Basin. The River Thames and Shadwell Basin constitute natural edges. The river can be accessed through the Thames Path, but the entrances to the pathway are often difficult to find. There is a publicly-accessible pathway along Shadwell Basin. The railway line is a built edge that constitutes a spatial barrier, separating north and south. Within the Central Area, the key east-west links are The Highway, Cable Street and Commercial Road. The neighbourhood has excellent transport links, including Shadwell DLR and Overground stations.

- ..... Central Area boundary
- Open space
- Water space
- - - - Natural edge (blue space)
- ////// Built edge
- ↔ Key vehicular link (A or B road)
- - - - Cycling route



**Introduction**

Stepney is largely a residential area with few shops scattered around and most commercial activity taking place along Mile End Road and Commercial Road. Its built form are reminders of both 19th Century Georgian and Victorian development, as well as post-war reconstruction.

- Open space
- Water space
- Neighbourhood centre

*‘Stepney City Farm, Mile End Park, canals, street art, good food, galleries, plus all the markets definitely make this a massive place for heritage and culture’ (local resident)*



**History**

In 1086 Stepney was listed in the Domesday Book. The medieval village grew up around the church of St Dunstan's, which was founded in AD 952 by the Archbishop of Canterbury and is the oldest church in east London. Stepney Green Park is on former common land that was once part of Mile End Green and it was the site of the Peasants Revolt in 1381 led by Wat Tyler. From the 17th Century the village, then known as Mile End Old Town, was a genteel retreat away from the crowded Thames-side hamlets, favoured by those who had profited from maritime industry and trade. The proximity to docklands has historically attracted Bengali sailors employed on commercial ships. The area today is a mix of post-war high-density housing, Victorian mansion blocks and the terraces that survived the slum clearances. Historic Stepney Green is regarded for its architecture, and many of the surrounding

streets including Arbour Square and York Square, contain Georgian and Victorian houses. Stepney's built heritage includes the Grade II listed former East London Synagogue of 1877 at 52 Rectory Square, now in use as apartments, its plain exterior contrasting with its richly ornamented interior. Nearby, off Stepney Green, the Grade II listed Stepney Jewish Primary and Infants School was built in 1906 and, after its closure in the 1960s, it was transformed into artist's studios, an early example of such a conversion in the East End.

- Open space
- Water space
- Conservation area
- Listed building

**Heritage**

Conservation areas in Stepney include Stepney Green, Albert Gardens, York Square, Carlton Square, St Peters, Carlton Square and Regent's Canal. The majority of these conservation areas manifest the housing developments of the early 19th Century, with numerous terraces and institutional buildings now listed. The Grade I listed St Dunstan and All Saints Church is an important Saxon Parish Church with commanding medieval additions that reveal its importance over time. Stepney Green Conservation Area is an area of exceptional architectural and historic interest, including the grand buildings along Mile End Road, the houses and mansion blocks (including Dunstan House) along Stepney Green and the picturesque aspect created by the mature trees of Stepney Green Gardens.



*St Dunstan and All Saints Church, within the York Square Conservation Area.*

**Townscape**

Stepney is largely a quiet residential neighbourhood off the high-traffic main arteries of Mile End Road and Commercial Street. The typologies vary widely in the area, from terraced housing and mansion houses to pre- and post-war council estates. The typologies are interlaced in clusters. After WWII, a large proportion of Stepney's terraces were replaced with housing estates such as Ocean Estate, Limehouse Estate, Stifford Estate, Clichy Estate and Mountmorres Estate. This was largely due to severe bomb damage in the area as well as slum clearances. They represent a mix of medium- to high-rise housing blocks and a number of terraced houses, including redevelopments in the 1990s and 2010s.

A substantial proportion of open space is found in Stepney. Open Spaces in the area include Stepney Green Park, St Dunstan's Churchyard, Whitehorse Road Park and Shandy Park as well as an urban farm. There is also easy access to Mile End Park. The areas around Commercial Road have an open space deficiency.

Typical building types



**A.** Long terraces along Mile End Road with a continuous building line and varying heights, most of them with commercial ground floor and 2-storeys residential above dating from early 19th Century.



**B.** Cressy House, a mansion block built in 1894 as a 4-storey housing development commissioned by East End Dwellings Company.



**C.** Post-war 1960s housing estate part of Ocean estate North, one of 6-storey blocks with continuous deck-access.

Typical building types



**D.** 1990s redevelopment of Limehouse Fields Estate. Brick terraces mimicking proportions and simplified details of 19th Century terraces nearby.



**E.** Limehouse Fields Estate, an original 1960s development with 2-3-storeys painted with stucco.



**F.** Uniform residential terraces with stuccoed lower storey and decorated with stucco mouldings built in 1829-1843, part of York Square Conservation Area.



**G.** Uniform, modest terraces of narrow flat-fronted houses within the Albert Gardens Conservation Area dating from circa 1820.



**H.** These 5-storey linear blocks and 13-storey tower form part of the Ocean Estate regeneration development completed in 2014 which included a new urban design approach and landscaping for the entire estate.



**Street pattern and movement**

Stepney has a predominantly regular street pattern south of Ben Jonson Road and irregular, more complex street pattern to the north, with ill-defined routes through the estates and many dead ends, making it difficult to navigate for pedestrians. Stepney experiences heavy traffic on its edges along Mile End Road and Commercial Road, both of which create barriers to north-south movement. The railway line to the south creates a built edge that is mostly permeable through regular openings. Regent's Canal is a natural edge that creates a barrier due to limited and hidden crossings. Stepney has good transport links, including Stepney Green Underground Station to the north and Limehouse DLR Station to the south.

- Open space
- Water space
- Natural edge (blue space)
- Built edge
- Key vehicular link (A or B road)
- Cycling route

This page is intentionally left blank





**Introduction**

Victoria Park is one of London's largest parks and the main green and leisure space in Tower Hamlets. It is designated as Metropolitan Open Space and it has been voted one of people's 10 favourite parks in the UK. It holds festivals, markets and other activities across the year. It is mainly surrounded by residential uses.

- ..... Central Area boundary
- Open space
- Water space

*'The open spaces of Victoria Park are especially valuable. Walking in nature, especially among trees, has proven health benefits.'* (local resident)



**History**

Victoria Park was created by an Act of Parliament in 1841 in response to public outcry about the lack of parkland in the East End and fears of disease among the large slum population. The Government bought up poor-quality land that had been used for market gardens, grazing and gravel digging. An alternative site lay on the Thames but it was deemed too expensive. James Pennethorne designed the park, which became instantly popular. It was extended in 1872 on land originally set aside for residential development. The park has been managed by a number of organisations such as the Metropolitan Board of Works (1887); the London County Council (1889); the Greater London Council (1965); Tower Hamlets and Hackney (1986); then solely Tower Hamlets (1994). Many of the parks' original features have been lost or have deteriorated over time. Parts of the site

were bombed during the WWII and have not been restored. Historically, the park has been used as a space for locals to meet, socialise and discuss politics and has held rallies of all persuasions, including 'the People's Army' supporting Suffragettes in 1913. One of Victoria Park's most iconic events was the revolutionary 'Rock against Racism' concert in 1978 organised to show unity against prejudice from far-right organisations demonstrating the power of music to highlight political issues.

- ..... Central Area boundary
- Open space
- Water space
- ▨ Conservation area
- Listed building

**Heritage**

Victoria Park is covered by the Victoria Park Conservation Area. It also includes the Regent's Canal Conservation Area to the west of the park. The former includes 19th Century residential terraces that have largely retained their traditional joinery details, slate roofs and stock brickwork. A uniform cornice line and surviving historic decoration, typical of the Victorian architectural style, contribute to a coherent and distinctive character in the area. Pockets of post-war development exist where terraces have been lost and redevelopment has occurred. The Regent's Canal Conservation Area is a linear conservation area with the boundaries drawn tightly around the canal and features associated with it including bridges, locks, lock cottages, warehouses and industrial features. Victoria Park is a Registered Park and Garden and is Grade II\* listed. The three bridges leading into the park are Scheduled Ancient Monuments. These are Bonner Hall Bridge, over Regent's Canal, Three Colt Bridge and Parnell Road Bridge, both over the Hertford Union Canal.



*The Scheduled Monument Three Colt Bridge, within the Victoria Park Conservation Area.*

**Townscape**

Victoria Park is a fine example of the English landscape park tradition, designed with sweeping lawns, informal tree plantings and irregular lakes. Roads in the area are broad and tree-lined, all reflecting the park setting. Victoria Park contains little built form but is surrounded by the buildings in Bow and Globe Town that front Regent's Canal and the Hertford Union Canal. Within the park some of the structures found are drinking fountains, pavilions and skateparks, both historic and more recently-developed ones. Immediately surrounding the park, Victorian terraces from the 1860s with 2-3 storeys are the prevalent typology.

Typical building types



**A.** *The Bonner Hall Bridge, designated as a Scheduled Monument, is a segmental arched bridge of red brick with prominent stone voussoirs. It was built between 1842-1845 around the same time as Victoria Park.*



**B.** *The Chinese Pagoda was acquired in 1847 from an exhibition in Knightsbridge.*



**C.** *The Victoria Park Pavilion built in late 20th Century as part of a government programme to encourage revival of interest in open spaces. The pavillion includes public toilets and a café.*

Typical building types



**D.** *Terraces of Italianate houses from circa 1865, on Old Ford Road, within the Victoria Park Conservation Area. They have paired doorways in flat arches on composite, engaged columns.*



**E.** *The Grade II\* listed Baroness Burdett Coutts Drinking Fountain, also known as Victoria Fountain, built in 1862. It displays a Gothic-cum-Moorish style.*



This page is intentionally left blank

**Street pattern and movement**

With Victoria Park being the dominating feature, the area is primarily comprised by generous open space. The built form in the immediate surrounding has a regular street pattern with good degrees of movement and legibility. Victoria Park has 2 key links: Old Ford Road from west to east, and Grove Road from south to north. The park is filled with pedestrian pathways, although there are limited entrances. Hertford Union Canal to the south and Regent's Canal to the west act as natural edges and they are publicly-accessible on the park side. The north side of Victoria Park marks the boundary of Tower Hamlets. Outside of the Central Area, the A12 acts as a built edge. Victoria Park has generally poor transport links, with no stations in close proximity.

- ..... Central Area boundary
- Open space
- Water space
- - - Natural edge (blue space)
- //// Built edge
- ↔ Key vehicular link (A or B road)
- - - Cycling route



**Introduction**

Wapping is a riverside neighbourhood. The stretch of it included in the Central Area is primarily a residential area, with the exception of a few shops and offices interspersed around the area and concentrated on Wapping Lane and Wapping High Street, and Princess Court Business Park to the north. Wapping's industrial heritage is made apparent by the remaining warehouses and wharfs converted into residential use.

- ..... Central Area boundary
- Open space
- Water space
- Neighbourhood centre

*'Wapping has a great sense of community with Wapping Lane shopping area which has a "village-like" quality and many small parks. It also feels more intimate and isolated by being cut off by the Highway'.*  
(local resident)



**History**

Wapping's name comes from the original Saxon settlement of 'Waeppa's people' and the area was largely marshland until the 14th Century. From the 16th Century, Wapping gained infamy as a place of execution. In the 17th Century, sailor's cottages existed alongside seafaring industries, while merchandise from abroad such as rum, ivory and gold trundled up and down Wapping High Street. With commerce increasing, the district continued to grow with Irish, Jewish, Scandinavian immigrants and freed slaves from the Caribbean joining the local population. In the 19th Century, Wapping alleyways were described as with 'the air suffused with the smells of exotic goods, and the sound of different languages echoing along the wharves'. The docks attracted seamen known as 'lascars', mainly from maritime areas of Gujarat and Malabar on the west coast of India and the

region now known as Bangladesh. Wapping was also the setting of many of Dickens' novels. When the Docks were built in the early 19th Century, in many respects the heart was torn out of Old Wapping: houses and workshops were lost, and the area's population diminished. St Katharine Docks and the former London Docks cut the area off from the City of London and the East End, breeding a special 'island' culture.

- ..... Central Area boundary
- Open space
- Water space
- ▨ Conservation area
- Listed building

**Heritage**

The extent of Wapping that falls within the Central Area includes the Wapping Pierhead and Wapping Wall conservation areas. The Wapping Pierhead Conservation Area is named after what was originally the main entrance from the River Thames into the London Docks. It includes the former entrance to the London Docks and 19th Century riverside warehouses, some of them Grade II listed. The conservation area also comprises open spaces, including Wapping Gardens, built in 1886 on the site of a slum clearance. Part of the Wapping Wall Conservation Area falls within Wapping. It mainly comprises warehouse and wharf developments from the 19th Century, some of them Grade II listed, with one of London's finest stretches of riverside industrial heritage. Glimpses of the riverfront over historic stairs are afforded through breaks in the barrier of buildings lining Wapping Wall, forming reminders of former public access to the river banks. Only a very small part of The Tower of London Conservation Area falls within Wapping.



*The Grade I listed former warehouse, built in 1813.*

**Townscape**

Wapping is largely a residential area, with the exception of some shops and offices. The main typology found are 19th Century warehouses and wharfs converted into mixed and residential uses in the late 20th Century, with average heights of 5-6 storeys. The area also includes brand new developments from late 20th Century and early 21st Century on bomb-damaged streets or on the site of the former London Docks, now partially occupied by a low-rise residential scheme with houses with up to 3 storeys. The highest element in the area is 21 Wapping Lane, a residential development with up to 19 storeys completed in 2012. Wapping also includes some council estates to the north, with blocks with up to 5 storeys. Despite the varying typologies, there is a consistent feel to the area's townscape thanks to its industrial heritage and overall consistency of materials, including in some of the more recent developments.

Parks in Wapping are of small- and medium-scale but distributed across the area they provide pockets of accessible open space to most of the neighbourhood. The largest open spaces are the Hermitage Riverside Memorial Garden, Wapping Gardens, Wapping Rose Gardens and Wapping Woods. Areas around Kennet Street and Hermitage Basin have an open space deficiency.

Typical building types



**A.** Late 20th Century 2-3 storeys-high Sir Thomas More Court built in brick.



**B.** Reardon House, part of the Wapping Estate built through slum clearance in the 1920s by the London County Council. It comprises Neo-Georgian blocks of 5 storeys.



**C.** Post-war 5-storey housing block on Prusom Street, of yellow brick with bay windows.

Typical building types



**D.** Grade II listed New Crane Wharf built in 1873 and reinstated in 1885 on Wapping High Street, within the Wapping Wall Conservation Area. It was converted into residential use and shops in 1990 and it is of stock brick.



**E.** Early 18th Century 3-storey houses, on Wapping High Street, within the Wapping Pierhead Conservation Area. They are representative of riverside buildings built before the spread of warehouses.



**F.** The early 20th Century Vancouver House built by the London County Council on Reardon Path, within the Wapping Pierhead Conservation Area, in a Neo-Georgian style.



**G.** Grade II listed Oliver's Wharf built in 1880 on Wapping High Street, within the Wapping Pierhead Conservation Area, was Wapping's first warehouse to be converted into flats. It is of stock brick with red brick and stone dressings.



**H.** Residential developments of 6 storeys built in the 1990s and early 2000s facing the River Thames, on Wapping High Street, in an area that was damaged during WWII.



This page is intentionally left blank

**Street pattern and movement**

Wapping has a predominance of large urban blocks which, combined with a lack of publicly-accessible pathways and an irregular street pattern make it difficult to access the River Thames and compromise legibility. Wapping is fairly isolated from its neighbouring areas. The Highway to the north is a key east-west link. The River Thames to the south constitutes a natural edge. Parts of it can be accessed through the Thames Path and open spaces, although private developments and continuous rows of historic warehouses often make it difficult to access the river, which is glimpsed through gaps between the buildings. Ornamental Canal constitutes another natural edge and it has publicly-accessible pathways. Outside of the Central Area, St Katharine Docks is another natural edge. Wapping has no built edges and it has excellent transport links, including Wapping Overground Station.

- ..... Central Area boundary
- Open space
- Water space
- Natural edge (blue space)
- ↔ Key vehicular link (A or B road)
- Cycling route



# 4. Central Area housing typologies

4.1 Introduction

The previous chapter showcased typical building types, or typologies, found in each of the Central Area Character Places. This chapter now focuses specifically on the residential examples among these, by compiling and analysing typical residential building types and associated urban types, as explained on the following page.

Although this chapter was informed by typologies found in the Central Area, the same residential building types may be found in other parts of the borough. Applicants proposing developments elsewhere in Tower Hamlets are, therefore, also encouraged to refer to this chapter when developing proposals.

Each residential building type shown on the following page has its key characteristics, strengths and weaknesses described in this chapter.

When proposing new developments in the Central Area, applicants are expected to identify the urban and residential building types surrounding the site and to respond to the characteristics described in this chapter, as well as the ones identified in Chapter 3 - Central Area Character Places.



4.1 Introduction

**Urban type**

The urban types refer to the historic evolution of an area/plot which is reflected in what buildings stand there today. Under each urban type category, similar historic and current land uses, street structures and heritage designations are found.

**Residential building type**

A residential building type is a category of housing based on typical characteristics, including form, scale and site configuration.

**Urban type**

**Residential building type**

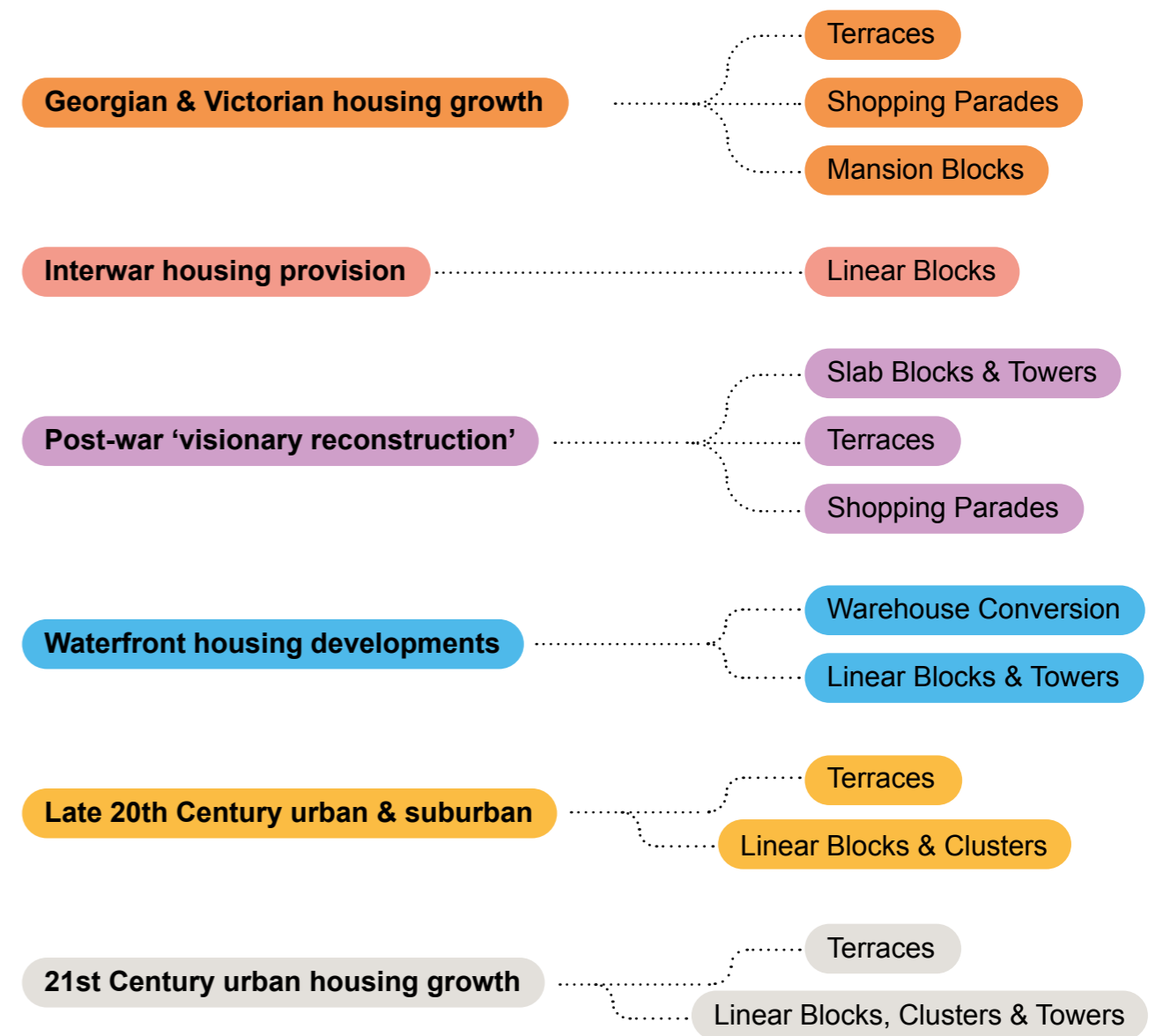

Figure 2: Classification of urban and residential building types.



**Urban type description**

During the late Georgian and Victorian periods Towers Hamlets underwent a significant growth. This typically took the form of a grid of small-scale streets and housing. Some of these buildings have been demolished or damaged in WWII and much of the remaining ones have statutory heritage protection.



**Opportunities & challenges**

Georgian and Victorian properties are often adaptable, however redevelopment may pose a risk to the area's character and inappropriate changes can harm the overall composition of the street. Many of these buildings are located in Conservation Areas and development is managed by Conservation Area Character Appraisals and Management Plans.

**Residential building type** Terraces

**Key characteristics**

- Uniform streetscape on a compact orthogonal (90°) grid
- 2-3 storeys-high
- Consistent building lines and heights
- Front the street with little to no set-back from pavement and entrances are clearly identifiable
- Clear distinction between private and public with railings, low wall or stairs creating defensible space at entrances
- Built in brick with brick and/or stucco detailing
- Most common roof form: vanishing gable roofs behind straight brick façade frontages (i.e. butterfly roofs), double pitch roofs without any parapets, mansard roofs
- Typically located in residential-only areas

**Strengths and weaknesses**

- Robust and well-proportioned buildings that promote a direct connection between homes and street, helping to foster a sense of community
- The consistency in façades and rooflines creates a strong, cohesive character
- Good balance between variety of detailing and consistency of overall composition
- Good balance between height of buildings and width of streets creating pleasant pedestrian environments
- Limited ability to provide for a variety of housing needs
- Buildings and adaptations require regular maintenance and often do not meet modern standards on aspects such as accessibility or sustainability requirements



Circa 1820 – Stepney.



1829-1843 – Stepney.



1865 – Victoria Park.

## Georgian & Victorian housing growth

### Residential building type Shopping Parades

#### Key characteristics

- Irregular streetscape in places
- 2-3 storeys-high with ground floor shop (some retrofitted) and usually residential above
- Similar overall heights, with taller buildings usually on street corners
- Front the street with short to no set-back from pavement
- Built in brick with brick and/or stucco detailing and with a variety of materials used in the shopfronts
- Vanishing gable roofs behind a straight brick frontage façade or mansard roofs
- Typically located in district and neighbourhood centres

#### Strengths and weaknesses

- Upper floors display a good balance between variety and consistency of materials and overall composition
- Good balance between height of buildings and width of streets
- Mix of uses animate area and provide focal point for neighbourhoods
- Refitted shopfronts often display poor-quality materials and projecting signage which are not sympathetic to the overall building and detract from the quality of the streetscape

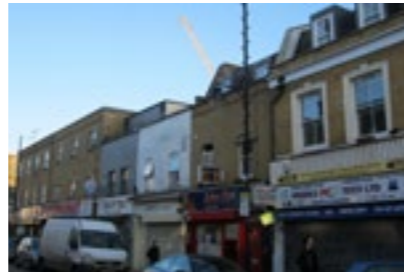

*Varying dates – Bow.*



*Mid-to late 19th Century – Mile End.*

This page is intentionally left blank

### Residential building type Mansion Blocks

#### Key characteristics

- Uniform streetscape and part of a tight urban block
- 4-5 storeys-high
- Front the street with short to no set-back from pavement and entrances are clearly identifiable
- Built in brick with regular fenestration patterns and elegant detailing around windows and entrances
- Composed rooflines with prominent chimney stacks and gables
- Typically located in residential-only areas

#### Strengths and weaknesses

- Robust and well-proportioned buildings that form a strong overall composition and are part of a strong urban grid
- Usually in the control of one owner, restricting piecemeal modifications that may damage the overall composition and allow for more comprehensive improvements



*1894 – Stepney.*

## Interwar housing provision

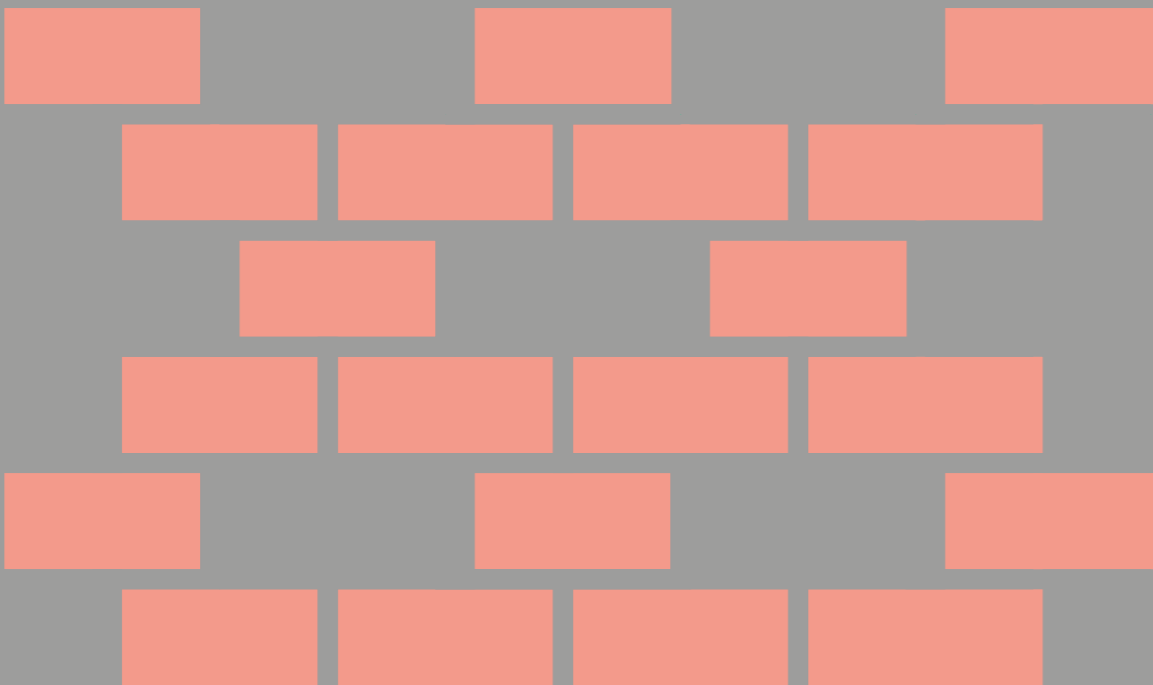

## Interwar housing provision

### Urban type description

By the start of the 20th Century, Tower Hamlets was densely populated and only a small number of housing developments took place between WWI and WWII. They primarily consisted of individual housing blocks of multi-occupancy.



### Opportunities & challenges

Interwar development often includes buildings that are somewhat isolated in their plots from the street, and there is an opportunity to improve this connection. Their scarce presence in the area, however, means that redevelopment needs to be carefully considered.

## Residential building type **Linear Blocks**

### Key characteristics

- Uniform buildings that are usually integrated into an urban block
- 4-5 storeys-high
- Consistent building line with deck-access elevations, often at rear, which give a strong horizontal emphasis
- Front the street with some set-back and entrances are not clearly identifiable
- Lack of clear distinction between private and public space for open/green spaces within development
- Built in dark red brick with Georgian proportions and regular fenestration patterns
- Most common roof form: hipped gable roof with regular chimney stacks
- Typically located in residential-only areas



1920s – Wapping.



1929 – Bow Common.

### Strengths and weaknesses

- Robust buildings
- Building frontage is usually lacking in entrances for the street interface, and therefore appears defensive
- Lack of definition between front and rear façades compromising security and legibility
- Relies heavily on the quality of the street and adjacent landscape
- Lack of connection to surrounding streets
- Often poorly designed public realm

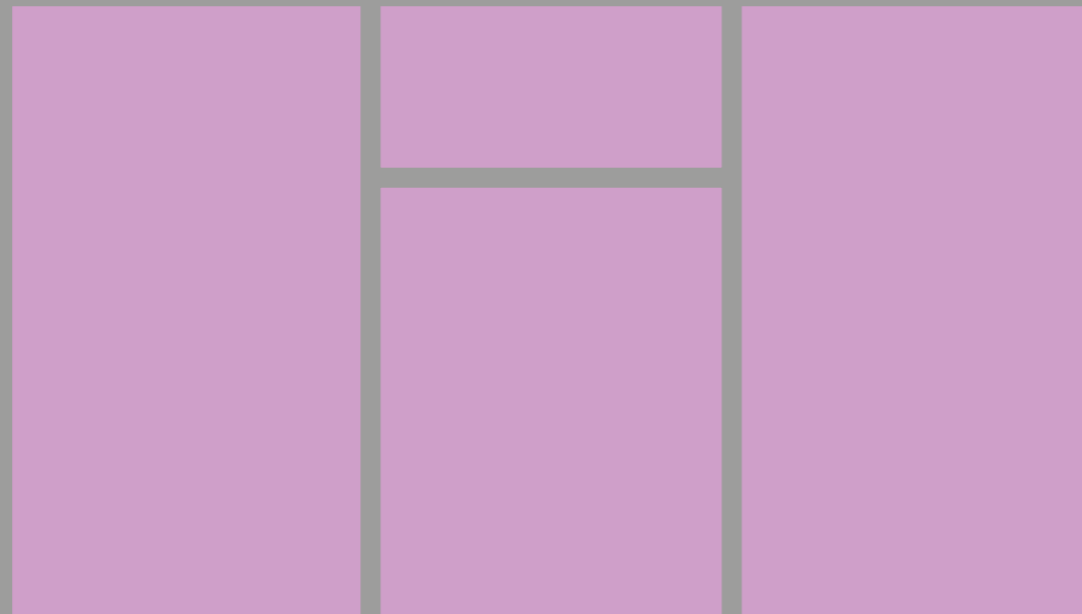

**Urban type description**

Following WWII, larger scale reconstruction and slum clearance developments took place across the borough between 1945-1985, mostly replacing areas once occupied by terraced housing.



**Opportunities & challenges**

Layouts and open spaces can be improved by building new homes, redeveloping redundant areas, better enclosing space and framing key movement routes. There is a threat, however, that piecemeal changes will not address underlying issues comprehensively and that insensitive alterations or demolition will lead to a weakening of architectural integrity.

**Residential building type** Slab Blocks & Towers

**Key characteristics**

- Free-standing buildings set within open space and entrances are not clearly identifiable
- Often part of a comprehensive development, including landmark towers of around 20 storeys and lower-rise 4-6-storeys slab blocks; often include one-storey garages
- Frequently comprise deck-access elevations
- Built principally in brick and/or concrete
- Mostly flat roofs, some long gable and hip gable roofs on the lower-rise elements
- Typically located in residential-only areas



1951 – Poplar.

**Strengths and weaknesses**

- Each development generally has a distinguishable style and can create a sense of place for residents
- Mostly robust buildings, designed to allow good light, views and ventilation to units, however this is not always achieved and materials are not always of high quality
- The varying building types within the same estate meet a diverse set of housing needs
- Social cohesion within development is often linked to the upkeep of communal spaces and buildings in general
- Large areas of open space but often of poor quality, including poorly designed public realm, lack of child-friendly outdoor spaces and poor lighting design in and around buildings
- Developments rarely address or respond to the surrounding context
- Properties are often laid out inward-looking with a lack of definition between front and rear façades compromising security and legibility
- Movement through estates is poor, with illegible and uninviting layouts for visitors restricting connections to streets and wider neighbourhood.



1968 – Globe Town.

## Postwar 'visionary reconstruction'

### Residential building type Terraces

#### Key characteristics

- An exception to the broader post-war reconstruction programme in Tower Hamlets, with most examples located in Stepney
- 2-3 storeys-high
- Consistent building lines and heights
- Front the street with short set-back from pavement and entrances are clearly identifiable
- Clear distinction between private and public with small front gardens, railings or low walls creating defensible space at entrances
- Plain-faced terraces of brick or concrete
- Mono-pitch or gable roofs
- Typically located in residential-only areas

#### Strengths and weaknesses

- Small groupings of houses give a sense of neighbourliness
- In narrow streets there is a good balance between height of buildings and width of streets creating pleasant pedestrian environments
- In some instances there is a lack of enclosure where streets are too wide and taken over by parking and balance between height of buildings and width of streets is relatively suburban
- Low-quality materials and detailing



1960s – Stepney.

## Postwar 'visionary reconstruction'

### Residential building type Shopping Parades

#### Key characteristics

- Ground floor shopping amenities integrated into linear blocks with residential units above
- 3 storeys-high
- Front the street with short to no set-back from pavement or occur in pedestrianised environments
- Built in brick with a variety of materials used in the shopfronts
- Typically located in District and Neighbourhood centres

#### Strengths and weaknesses

- Good balance between height of buildings and width of streets
- Mix of uses animates area and provides focal point for neighbourhoods/estates
- If located in more internal, pedestrianised areas, shopping parades often lack visibility from outside the estate, resulting in a lower footfall
- Shopfronts often display poor-quality materials and signage which are not sympathetic to the overall building and detract from the quality of the streetscape



1951 – Poplar.



1958 – Limehouse.

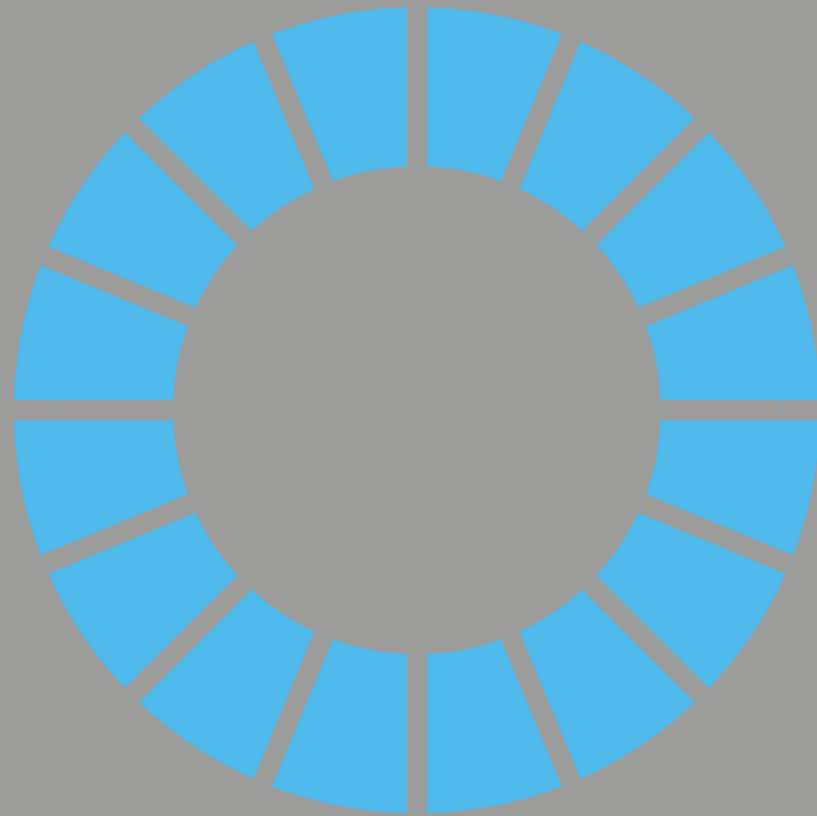

**Urban type description**

Warehouses mostly built in the 19th and 20th centuries and converted from the 1970s, and new builds along canals, basins and the River Thames. Often these developments close off public access to the water.



**Opportunities & challenges**

There are opportunities to develop underused buildings along the waterfront. There is a threat, however, that new development will not appropriately address the character of waterfronts or that it will close off public access to the water. Equally, increased densities need to be carefully balanced so as not to erase the historic grain of these areas.

**Residential building type** Warehouse Conversion

**Key characteristics**

- Usually 19th and 20th Century warehouses or other industrial buildings converted into residential or mixed use that face the riverside directly
- Free-standing or part of row of similar buildings
- Usually 4-6 storeys-high, with some lower-rise buildings such as along the canals
- Front the street with short to no set-back from pavement and entrances are usually identifiable albeit often these are gated
- Differentiation between street and waterfront façades
- Usually built in dark or stock brick
- Front-gabled façades or straight brick façade frontage behind vanishing gable roofs



1873 and converted in 1990 – Wapping.



1880 and converted in 1972 – Wapping.

**Strengths and weaknesses**

- Robust and well-proportioned buildings that even when found in individual plots have a cohesive group value
- Successful re-use and adaptation of important historic buildings, several of which are listed
- Good balance between variety of detailing and cohesiveness of industrial character
- In some occasions buildings led to unwelcome gated developments that that close off access to the water and diminish wider connection to the street
- Often significant alterations required to adapt warehouses for residential use and considerable level of specialism required for design and execution



Late 19th Century – Bow.



## Waterfront housing development

### Residential building type **Linear Blocks & Towers**

#### Key characteristics

- Usually late 20th or early 21st Century new build developments that sit directly facing the riverside and canals
- Free-standing blocks
- Usually 4-7 storeys-high with some taller elements in more recent developments
- Developments maximise views towards the water
- Differentiation between street and waterfront façades, the latter with larger openings to maximise views
- Variety of forms, materials and roofscapes

#### Strengths and weaknesses

- Some are successful examples of referencing of industrial character
- Proximity to and views towards blue infrastructure present well-being benefits
- Higher densities make better use of land and intensify urban areas
- Varying robustness and quality of materials
- Multi-storey, high density development requires good access to amenity spaces and public transport
- In some occasions buildings led to unwelcome gated developments that close off access to the Thames Path and diminish wider connection to the street, resulting in poor legibility and poorly designed public realm



1987 – Shadwell.



1998 – Limehouse.



1990s and early 2000s – Wapping.



2010s – Bow Common.

This page is intentionally left blank



**Urban type description**

Developments built between 1985-2000s moving away from the design of post-war re-construction and towards a more contextualized approach and human scale. Some developments have a clearer connection to the street and urban environment whilst others have a seemingly suburban character.



**Opportunities & challenges**

Densities can be increased through subdivisions or development of underused areas. This may pose, however, a risk to character and amenity, particularly in developments with a more suburban character.

**Residential building type Terraces**

**Key characteristics**

- Uniform streetscape
- 2-3 storeys-high
- Often inspired by/based on materials and forms of Georgian and Victorian housing including sparsely detailed façades
- Consistent building lines and heights
- Front the street with short to no set-back from pavement and entrances are clearly identifiable and individual to each dwelling
- Clear distinction between private and public with railings, low walls, defensible planting or car parking
- Comprise a variety of façade materials, including brick, wood panelling and render
- Typically located in more suburban-type settings



1990s – Stepney.



Late 20th Century – Wapping.

**Strengths and weaknesses**

- Mostly robust, well-proportioned buildings that form legible and compact blocks
- Small groupings of houses give a sense of neighbourliness and some include child-friendly spaces
- In narrow streets there is a good balance between height of buildings and width of streets creating pleasant pedestrian environments
- In some instances there is a lack of enclosure where streets are too wide and taken over by parking and balance between height of buildings and width of streets is relatively suburban
- Materials and details vary in quality, with some nicely detailed schemes, others of poor architectural composition
- Monolithic detailing at times creates less engaging environments
- Varying quality of urban design, some with poorly designed public realm and building frontage

Residential building type Linear Blocks & Clusters

Key characteristics

- Apartment blocks that may be free-standing within larger plots leaving areas of open space or may form tight urban blocks
- 3-4 storeys-high
- Often loosely inspired/based on materials and forms of Victorian and Georgian housing, however distinctively different in terms of scale and massing
- Front the street with short set-backs usually used for car parking and have shared entrances
- Clear distinction between private and public with marked entrances, gates, defensible planting or car parking
- Car access and parking is an integral element of the design and has often played a large part in determining the layout of the development
- Typically located in residential and mixed-use areas

Strengths and weaknesses

- Mostly robust, well-proportioned buildings that form legible and compact blocks
- Balance between layout of blocks being designed to allow good lighting and ventilation to units but still maintaining some relationship with street and surroundings
- Developments often foster a sense of community with strong connections across neighbours and some developments including child-friendly spaces
- Numerous schemes of poor architectural composition, details and materials
- Varying quality of urban design, some with poorly designed public realm and building frontage
- Movement through developments with open areas around blocks is poor due to lack of legibility and prioritisation of vehicular access



Late 20th Century – Globe Town.



Late 20th Century – Shadwell.



Late 20th Century – Mile End.

This page is intentionally left blank

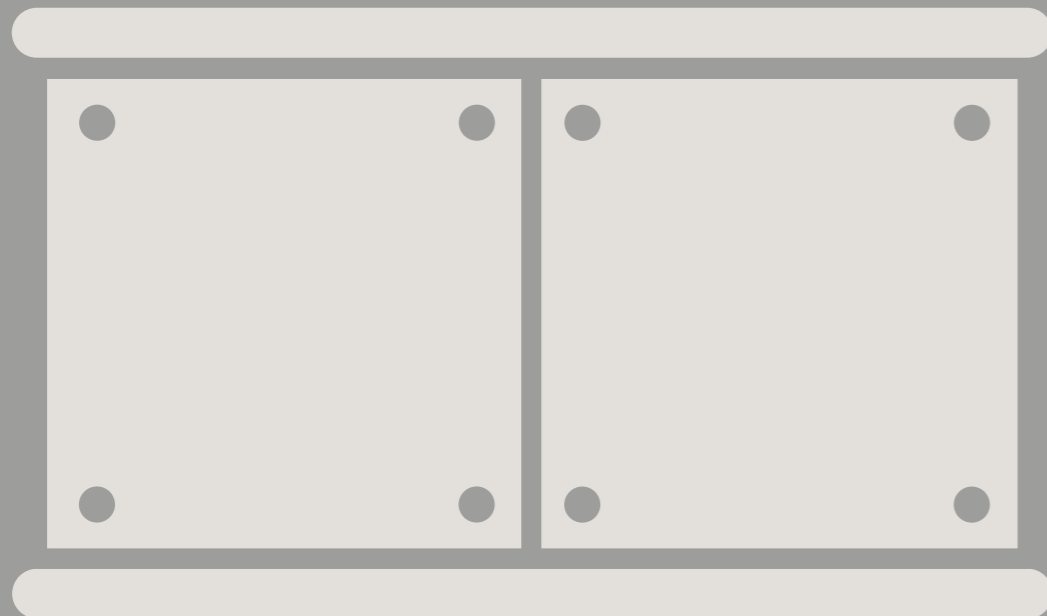

**Urban type description**

Pockets of new builds built since the 2000s through development of brownfield land, infill or more comprehensive redevelopment. The main characteristic is precisely the variation of scale, density, types and materials.



**Opportunities & challenges**

The variety provided through the range of building types sometimes leads to an unclear and fragmented character and there is an opportunity to improve the connection between developments and also to the wider street environment. There is a risk that new developments may reinforce fragmentary character and lack of cohesion by following these precedents.

**Residential building type** Terraces

**Key characteristics**

- Uniform streetscape although buildings are often set-back from the pavement with car parking in front of entrances and or cul-de-sacs diminishing connection to street environment
- 2-3 storeys-high
- Buildings have a domestic scale with some reference to Georgian and Victorian terraces
- Consistent building lines and heights
- Front the street and entrances area clearly identifiable and individual to each dwelling
- Clear distinction between private and public with marked entrances, defensible planting or car parking
- Comprise a variety of façade materials, including brick, wood panelling and render
- Typically located in more suburban-type settings



*Early 21st Century – Shadwell.*

**Strengths and weaknesses**

- Mostly robust, well-proportioned buildings that form legible and compact blocks
- Small groupings of houses give a sense of neighbourliness
- Provide off-street parking to residents, something rare in the borough
- Often there is a lack of enclosure where streets are too wide and taken over by parking and balance between height of buildings and width of streets is relatively suburban
- Suburban character and monolithic detailing create less engaging environments
- Some are of poor architectural detailing and materials
- Large set-backs for parking create a weak streetscene
- Low densities and prevalence of parking result in a inefficient use of land
- Numerous schemes have poorly-designed landscaping

Residential building type Linear Blocks, Clusters & Towers

Key characteristics

- Typifies the new type of planning and urban design introduced by the 'Urban Task Force Report: Towards an Urban Renaissance' which encouraged re-use of brownfield land, higher densities and mixed-use
- Apartment blocks with shared entrances, some with commercial or retail uses on ground floor
- 4+ storeys-high blocks with a varying relationship with surrounding streetscape
- Front the street with short to no set-back from pavement
- Push for a distinction between private and public with marked entrances, defensible planting or gates/railings
- Provision of a mix of housing types reflects the diversity of housing need and more recent specialist demands such as for student housing
- Often includes seemingly arbitrary break in materials to break up massing for it to appear smaller at street level
- Comprise a variety of façade and cladding materials, including brick, render, concrete, steel, aluminium
- Very little or no car parking (apart from disabled parking)
- Typically located in residential and mixed-use areas

Strengths and weaknesses

- May create local landmarks and focal points by being strikingly different to surrounding buildings
- Mixed-uses animate areas
- Fittings and equipment are installed to modern standards (i.e. in bathrooms and kitchens)
- Higher densities make better use of land
- New buildings and modern materials can provide a fresh feel to the area and improve security and safety through improved urban design and good lighting strategy
- Successful developments have integrated green spaces and communal areas such as roof terraces and gardens
- Varying robustness and quality of materials, some are of poor architectural quality and have low-quality materials with little regard to surrounding character
- Multi-storey, high density development requires good access to amenity spaces and public transport
- Single-aspect flats and minimum space standards give little adaptability and poor long-term liveability
- When gated and isolated, developments often create a poor relationship with the wider street environment and the community



2010s – Mile End.



2000s – Poplar.



2012 – Mile End.



2018 – Bow Common.

This page is intentionally left blank

# Part B

# Guidelines for Good Growth

# 5. Character-based growth principles

By understanding the character of different parts of the borough, the capacity for individual development sites to change can be determined. Any change that occurs must strike a balance between the need to provide new homes and the need to respect the established and valued character of the area. In many cases change will be expected to **reinforce** established patterns of development such as building type, scale, street pattern and frontage. In some case it may be appropriate for the redevelopment of a site to **mediate** between exiting building types of differing character. In limited circumstances there will be the opportunity for new development to **reinvent** a site by introducing new building types and creating new street patterns and frontage. This chapter describes the most common types of sites that fall under each of these categories. It also provides principles to guide the establishment of a vision for sites. A summary of each of the character-based growth principles can be found in the following page's diagram.

Determining the suitability for each type of growth principle should be informed by **Part A: Character appraisal** of this SPD and the descriptions and examples included in this chapter. The character-based growth principles should be used to help applicants develop an appropriate context-led vision for a site at the early design stages. They should be complemented by the more detailed design guidelines in Chapter 6 - Design toolkit for small sites. The character-based growth principles refer to the same types of sites that are addressed in further detail by Chapter 6. Proposals should also respond to Chapter 7 - Design principles for residential developments.

When evaluating whether a site is suitable for Reinforcement, Mediation or Reinvention, it is important to consider which elements of the surroundings are

likely to be maintained through time or might be redeveloped. Some of the guiding elements that can be used to assess that is whether these elements comprise robust and well-proportioned typologies; whether they portray relevant historic or character elements of an area and/or whether they are covered by additional protection such as statutory or local listing or conservation areas. The character-based growth principles are contained within a spectrum of change and should be agreed between applicants and the council at early discussions about a site and proposed development. Each of them is presented in a blue textbox in the following pages and further information on what the principle entails/how to achieve the principle is found below it in bullet points.

Case-studies have been chosen to illustrate each of the character-based growth principles. It should be noted, however, that no building is exemplary in all respects and case studies may underperform against other criteria. Captions highlight what is particularly successful about each example.

This section provides additional guidance to the Tower Hamlets Local Plan 2031 policies S.SG1: Areas of growth and opportunity within Tower Hamlets and S.SG2: Delivering sustainable growth in Tower Hamlets, particularly in regard to managing growth to achieve developments that respond to and enhance existing character. If sites are within or adjacent to a conservation area or listed building; would have an effect on a conservation area or listed building (and/or to their settings); or if there is a listed building within the site, applicants should refer to additional heritage guidance such as the Tower Hamlets Conservation Strategy 2027, Conservation Area Character Appraisals and Management Plans, and the Planning (Listed Buildings and Conservation Areas) Act 1990.

**Scope of change anticipated for small sites in the Central Area**

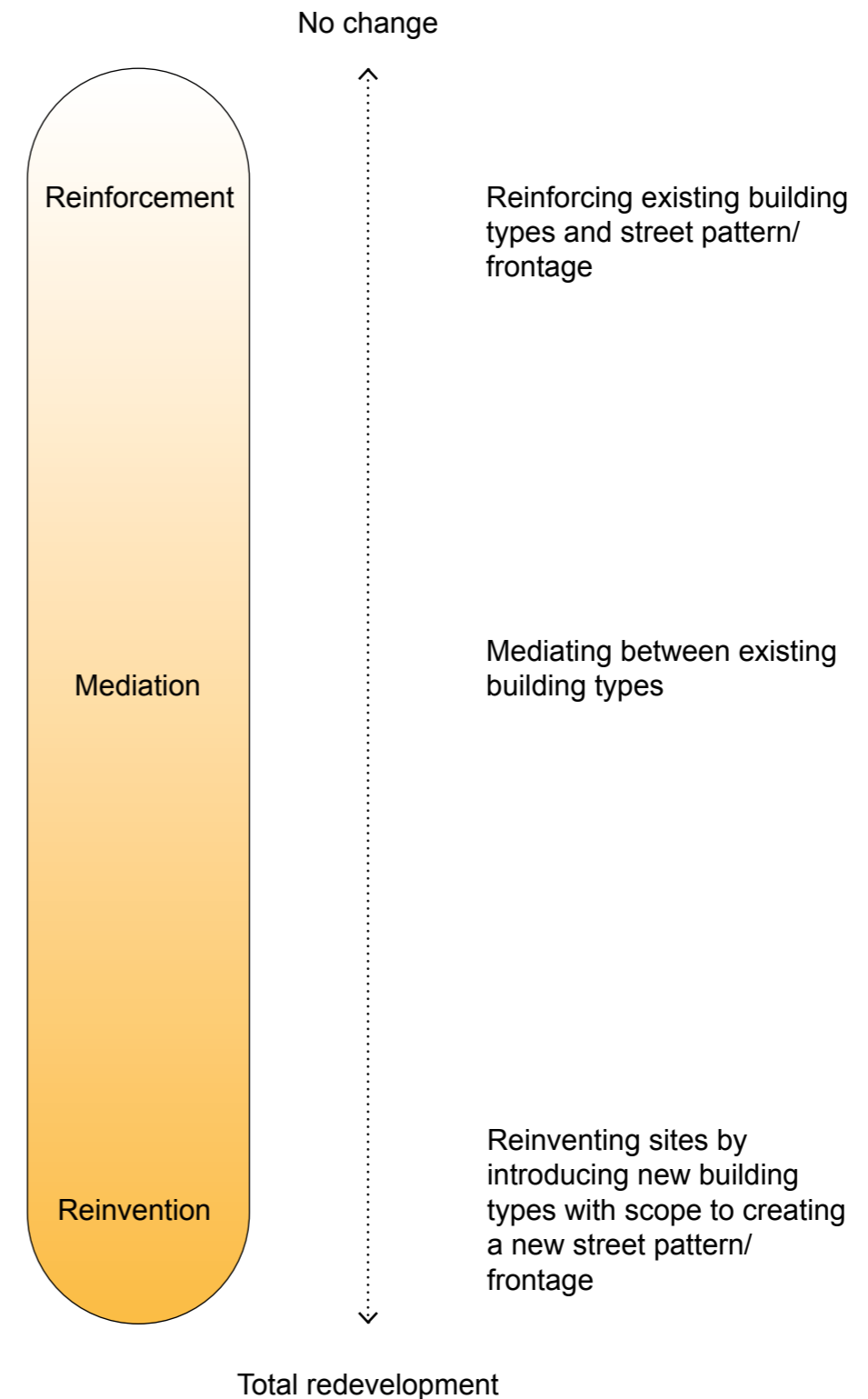

Figure 3: Scope of change



## 5.2 Reinforcement

**Character-based growth principle:**  
Developments should reinforce existing building types and street pattern/ frontage.

### Identification

Sites will likely:

- Contain a defined street pattern and street frontage which will inform the proposed development.
- Contain a robust and cohesive character within its boundaries or in its immediate surrounding and may be in a conservation area and/or include statutorily and locally listed buildings.
- Be Streetscape infill; Corner infill; Block extension; Roof extension or Rear extension (applicants should also refer to detailed guidance for each of these provided by Chapter 6 - Design toolkit for small sites).

### Guidance:

- Developments should be in line with surrounding scale, proportions, form, height (including shoulder height) and density.
- Developments should follow the existing street pattern and/or street frontage.
- Development should use high-quality, durable materials that respond sympathetically to surrounding palette.
- There might be opportunity for developments to integrate more playful façade compositions that respond sympathetically to surrounding design.
- Developments should re-stitch urban fabric and complete the streetscape.

## 5.2 Reinforcement



*52 Tredegar Square: A new development that closely follows existing proportions, materials and detailing of adjoining buildings on the terrace. (photo ©Ivan Jones)*



*Salmen House: A new development that follows massing, building line and roof form of adjoining buildings on the terrace whilst integrating playful use of materials and colours into the façade composition. (photo ©French + Tye)*

### 5.3 Mediation

#### Character-based growth principle:

Developments should mediate between existing building types that are lacking in group cohesiveness, whilst following established street pattern/frontage.

- Developments should use high-quality, durable materials that respond sympathetically to surrounding palette.
- There might be opportunity for developments to integrate more playful façade compositions that respond sympathetically to surrounding design.
- Developments should re-stitch or repair urban fabric and complete the streetscape, while carefully introducing new character elements that mark a mediation between existing elements or a transition between existing and future character.

#### Identification

Sites will likely:

- Contain a defined street pattern and street frontage which will inform the proposed development.
- Contain a varied character within its boundaries or in its immediate surrounding due to different building types and/or to a varying degree of well and poorly-maintained elements.
- Be Streetscape infill; Corner infill; Block extension; Garden infill; Backland; Roof extension; Rear extension (applicants should also refer to detailed guidance for each of these provided by Chapter 6 - Design toolkit for small sites).

#### Guidance:

- Developments should mediate between surrounding scale, proportions, form, height (including shoulder height) and density, and carefully respond to it with some scope for increases in height, density and massing.
- Developments should follow the existing street pattern and/or street frontage.
- Developments should consider different character of streets if the site faces more than one and respond to each in a suitable way.

### 5.3 Mediation



229-236 Armagh Road: An estate infill development that mediates between surrounding heights and proportions and that uses a traditional material (brick). (photo ©Ivan Jones)



49 Derbyshire Street: The streetscape infill development (rendered image of approved scheme) implements materials that integrate well with surrounding buildings whilst mediating between the different heights and typologies. (image ©Rivington Street Studio)

**Character-based growth principle:** Developments should reinvent sites by introducing new building types with scope to creating a new street pattern/ frontage and higher densities.

**Identification**

Sites will likely:

- Contain a varied character within its boundaries or in its immediate surrounding due to different building types and/or to a varying degree of well and poorly-maintained elements. Sites may also currently house unsuitable elements in terms of land-use and/or streetscape, leading to a lack of character cohesiveness.
- In some specific instances, where a new local landmark might be appropriate, such as on prominent corner plots, reinvention may also be suitable on sites with more cohesive character.
- Be Streetscape infill; Corner infill; Garden infill; Backland; Detached site or Roof extension (refer to detailed guidance for each of these in Chapter 6 - Design toolkit for small sites).

**Guidance:**

- Developments should be in line with wider Central Area character, but there may be scope for proposing additional height, density and massing than immediate surrounding and/or current uses in the site as well as innovative forms.
- Developments should consider different character of streets if the site faces more than one and respond to each in a suitable way.

- Developments should use high-quality, durable materials that respond sympathetically to surrounding palette.
- Developments may integrate more playful forms, façade compositions and distinct elements into the design.

In addition to the guidance above, and depending on whether the site has a defined street pattern/frontage or not, one of two types of Reinvention may apply for the purposes of this SPD: Building Reinvention or Urban Reinvention.

**1. Building reinvention**

Developments introduce a new building type within a defined street pattern and/or street frontage.

- Developments should re-stitch or repair urban fabric while following the street frontage and completing the streetscape with a building that stands out as an innovative integration into the street.

**2. Urban reinvention**

Developments introduce a new building type that does not follow existing street patterns and/or street frontages.

- Developments should integrate a new pedestrian-friendly street frontage into the urban landscape with a building that introduces an innovative change to the existing urban block.



**Building reinvention:** Old Ford Road: The development introduces a contemporary building design whilst following the defined street pattern and street frontage. (photo ©Tim Soar)



**Urban reinvention:** Hannibal Road Gardens: By redeveloping a former garage site, the development creates a new street pattern and street frontage in addition to introducing a contemporary building design. (photo ©Morley von Sternberg & Peter Barber Architects)

# 6. Design toolkit for small sites

As highlighted in the Introduction to the SPD, small sites offer a variety of development opportunities, ranging from modest extensions of existing buildings to new build developments on sites of up to 0.25 hectares. The guidance presented in this chapter therefore applies to both extensions to existing dwellings as well as the creation of new dwellings. Small sites may also occur in a range of urban conditions, including both street-facing and backland development, as well as sites that are connected to an adjacent building or that are detached. This chapter looks at the most common types of small sites found in the Central Area, as well as the most common surrounding contexts, i.e. existing residential building types found next to sites (also refer to Chapter 4 - Central Area housing typologies).

Each type of site and associated context is analysed and design guidelines are provided. These are based on best-practice architecture and urban design considerations that reflect the council's aspirations. Applicants that do not comply with the guidelines will need to provide robust justification and demonstrate how their proposal meets exceptional design standards. This chapter does not pre-determine Development Management decisions, and each site and proposal will be judged on a case-by-case basis.

The guidelines should be read in conjunction with **Part A: Character appraisal** of this SPD, as well as chapters 5 - Character-based growth principles and 7 - Design principles for residential developments. Proposals should respond to the guidelines included in the three chapters forming **Part B: Guidelines for Good Growth**.

Case-studies have been chosen to illustrate each site type. It should be noted, however, that no building is exemplary in all respects

and case studies may under-perform against other criteria. Captions highlight what is particularly successful about each example.

Applicants are expected to refer to the Tower Hamlets Local Plan 2031 and associated interactive Policies Map to see a full list of policy requirements. As noted in the Introduction to the SPD, minor and major developments will have different requirements relating to matters such as affordable housing and amenity space (private, communal and play space) provisions and applicants should refer to these in the Tower Hamlets Local Plan 2031 and Planning Obligations SPD 2021. If sites are within or adjacent to a conservation area or listed building; would have an effect on a conservation area or listed building (and/or to their settings); or if there is a listed building within the site, applicants should refer to additional heritage guidance such as the Tower Hamlets Conservation Strategy 2027, Conservation Area Character Appraisals and Management Plans, and the Planning (Listed Buildings and Conservation Areas) Act 1990.

Most Victorian and Georgian terraces within the Central Area are located in conservation areas. Generally, planning permission to roof extensions will not be granted due to the potential for harm to the historic environment, with the exception of some conservation areas where Conservation Area Character Appraisals and Management Plans set clear design requirements which extensions need to comply with to be considered acceptable. This chapter does not cover these circumstances. If a proposal falls under these described conditions, applicants should refer to the appropriate Conservation Area Character Appraisals and Management Plans.

Applicants should identify the type of site they are working on through the diagrams in the following pages and the descriptions provided for each of them. In some instances, sites may include elements from more than one site type; applicants should, in these cases, refer to the guidelines for the different types of sites that are relevant.

Each site-type starts with Site-type specific considerations. For each associated context the chapter then runs through three topics: Footprint and site layout; Built form; and Design and appearance. The text is accompanied by diagrams showing the site on plan, in section and in axonometric. Sites are shown as empty plots, although guidelines also apply to redevelopments.

The diagrams are used to illustrate key elements that should be taken into account. They do not, however, show literal indications of acceptable massing, footprint or height, but rather a built parameter to guide developments' massing and built form. The parameters are shaped by several elements, such as outlook and daylight/sunlight considerations (based, in particular, on the BRE 25° and 45° lines); street proportions, defensible space; privacy distances and building lines. These provide good starting guidelines for acceptable massing and built form.

In the diagrams:

- Blue is used to refer to design considerations that respond to the surrounding urban context, such as following existing street pattern and building lines and important views to consider.











- Orange is used to refer to impact considerations, such as access to daylight/sunlight by neighbouring



buildings and defensible space, which marks the frontier between private and public spheres.

At the end of the chapter, common constraints found in the Central Area are also highlighted and the topics of Footprint and site layout and Design and appearance are addressed for these, once more with accompanying diagrams of sites. The same considerations described above for diagrams apply.

**Guidance key**

-  Impact considerations
-  Contextual design considerations
-  Building heights or shoulder lines
-  Follow contextual street proportions
-  Potential set-back storey (where context, outlook and daylight/sunlight implications allow)
-  Potential additional storey (where context, outlook and daylight/sunlight implications allow)
-  Example important views to show in 3D visualisations
-  Section line

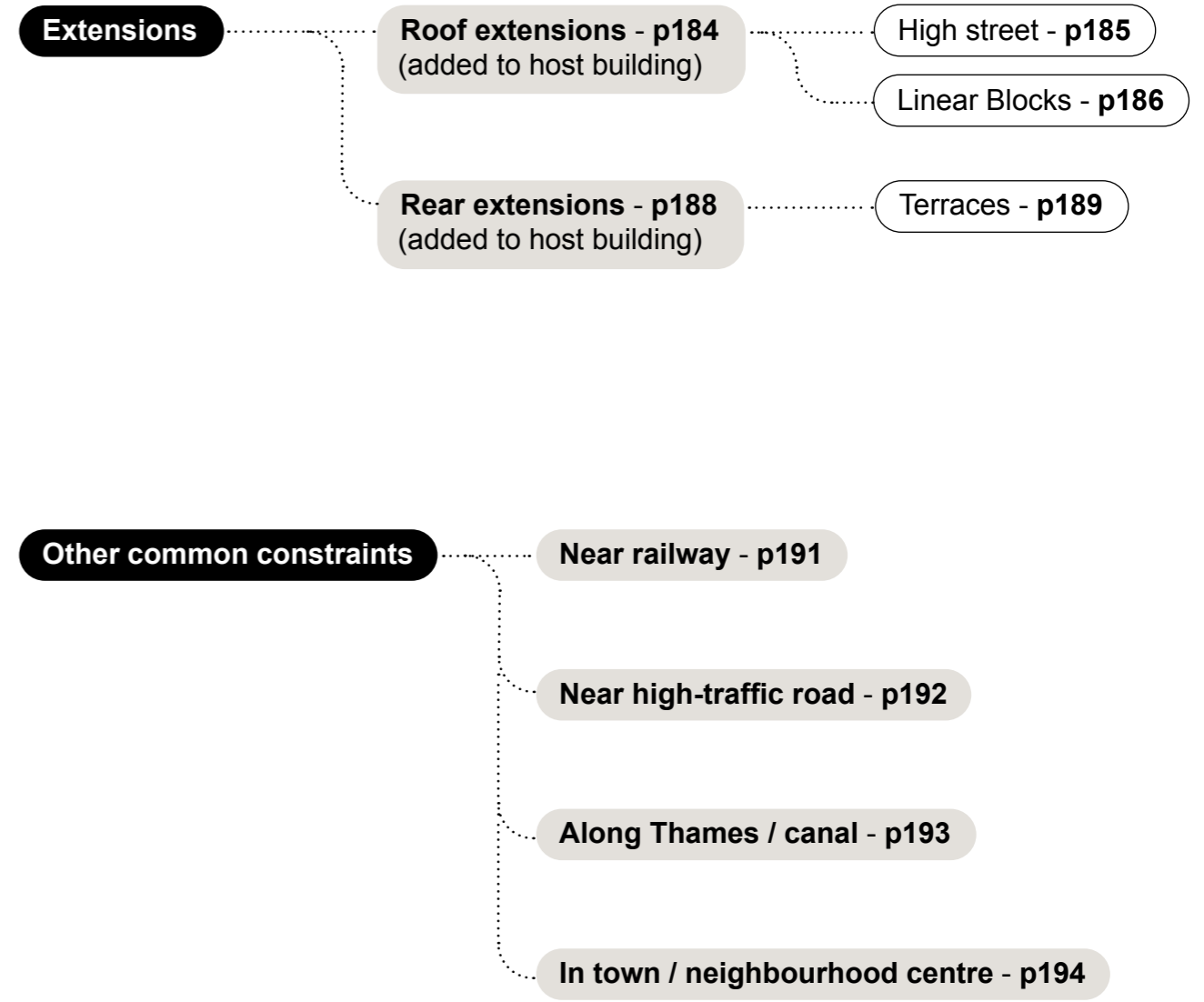
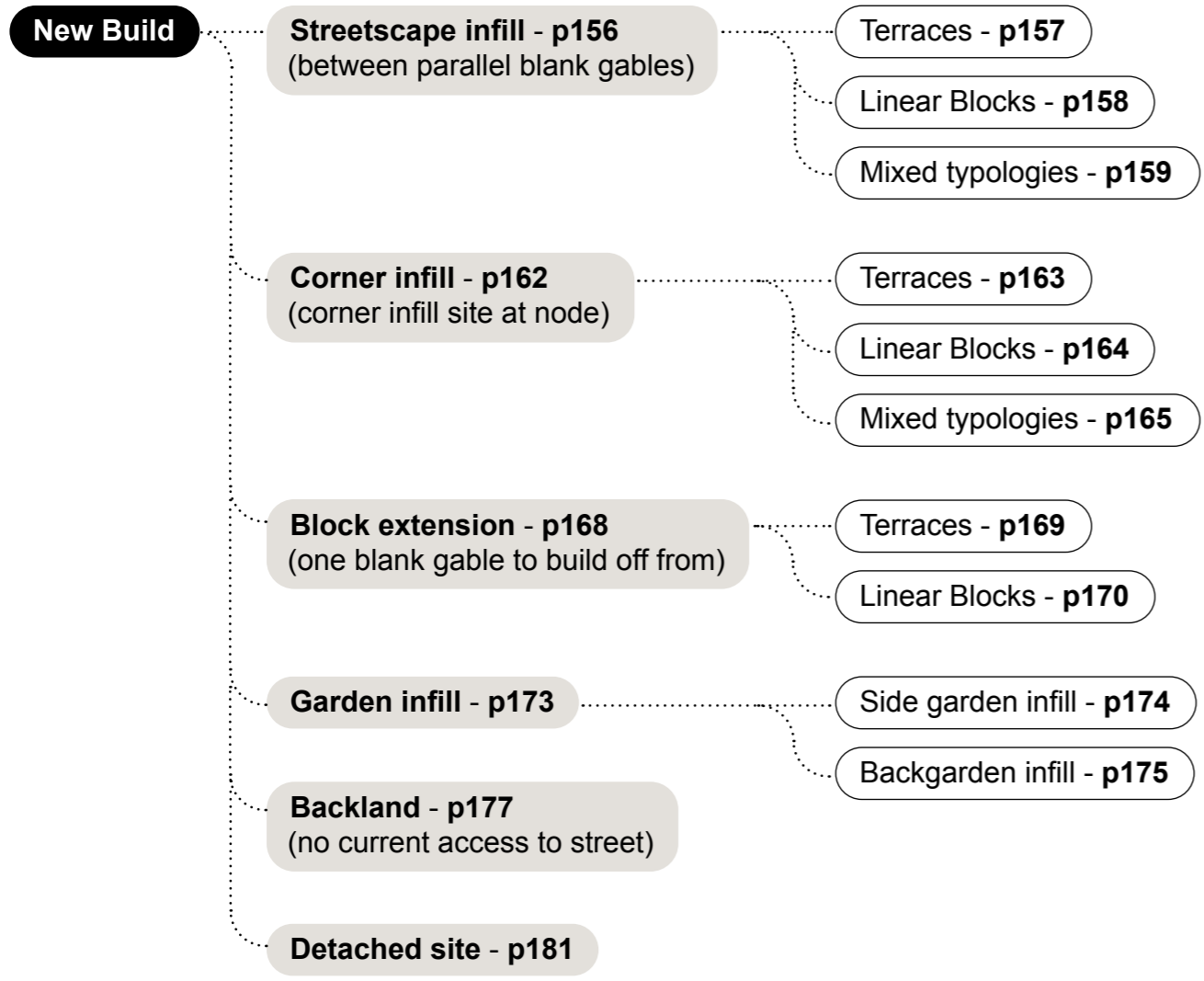

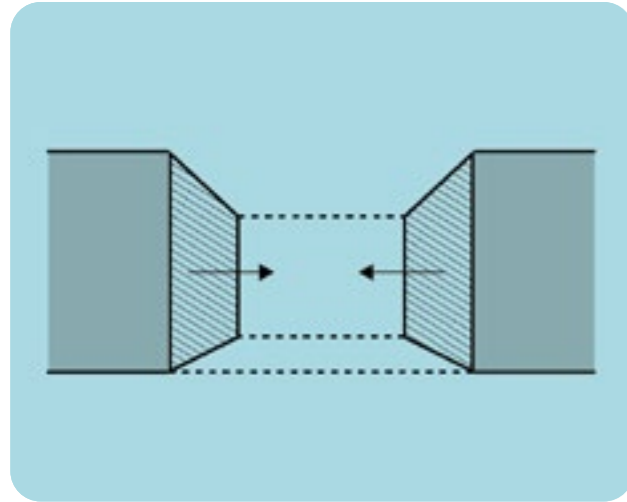
**New build****Streetscape infill**  
(between parallel blank gables)**Description**

A site with direct access to the street and framed by two parallel blank walls from adjacent buildings. The adjacent buildings can be of the same or different typologies.

**Site-type specific considerations**

- A good understanding of how the streetscape might evolve is important so as to avoid hindering future development.
- The site might allow developments to include an access route to a backland development or a mews development to optimise site coverage.
- Applicants should set out the details of where the new development abuts the existing building. This junction needs to be carefully considered for materiality, durability and composition.
- Appropriate levels of privacy and daylight/sunlight must be secured to new and existing dwellings.

**New build****Streetscape infill**  
(between parallel blank gables)**Terraces****Footprint & site layout**

- Developments should follow the established front and rear building lines of adjacent buildings on the same terrace.

**Built form**

- A key characteristic of terraced streets is their consistent eaves and roofline. This consistency presents opportunities for developments to promote continuity. Where there is consistency, the development's massing, eaves line, parapet line and roof form should follow those of adjacent buildings on the terrace.

**Design & appearance**

- Where new building façades are proposed within an existing terrace, the design of these should respect the vertical rhythm and proportions of neighbouring buildings.
- Where replicating architectural elements (such as single-glazed windows, accessibility barriers) would be against current regulations, applicants are encouraged to suggest suitable alternatives that are in line with the development's design vision.
- Defensible space and landscaping should be carefully designed and integrated into the street pattern.
- To avoid detracting from building line, inset balconies and rear roof terraces may be more appropriate for private and communal amenity space. Any potential privacy issues will need to be mitigated through careful design.

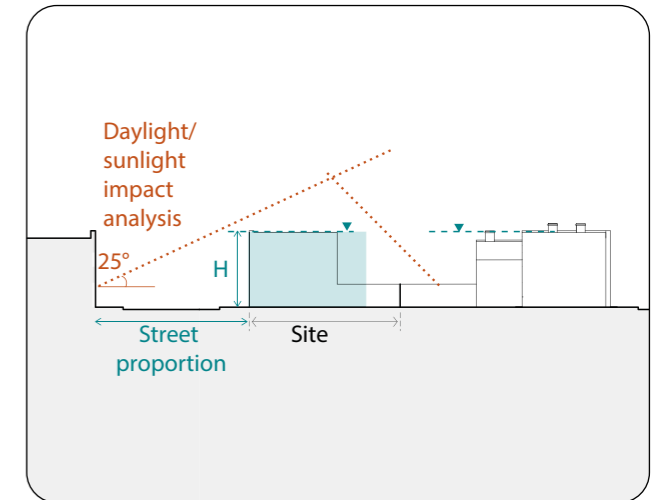
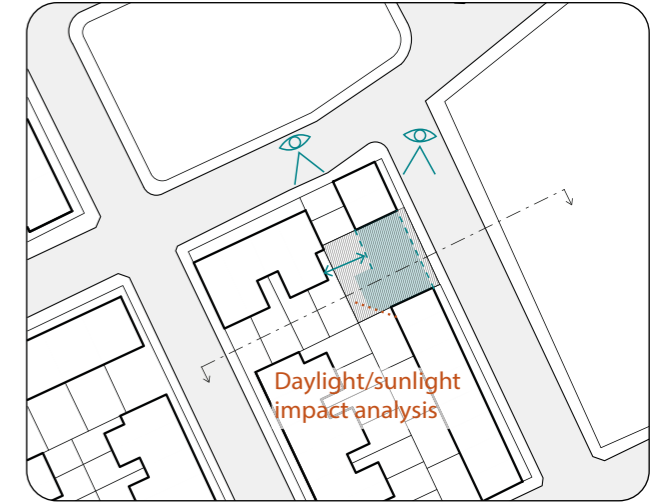
**Character-growth principles**

Suitable for: **Reinforcement** **Mediation**

**Footprint & site layout**

- Developments should follow the defined front building lines of adjacent linear blocks where they are consistent.
- Any changes in pedestrian circulation should demonstrate an improvement.

**Built form**

- The massing and roof form should follow that of surrounding linear blocks.

**Design & appearance**

- Façade design should reflect the emphasis and proportions of neighbouring development. Linear blocks will often display a horizontal emphasis and regular proportions which developments should relate to.
- Defensible space and landscaping should be carefully designed and integrated into the street pattern.
- If private amenity space is to be provided through balconies, they should not project over the pavement. Where the street is characterised by recessed balconies, these should be incorporated in the design.

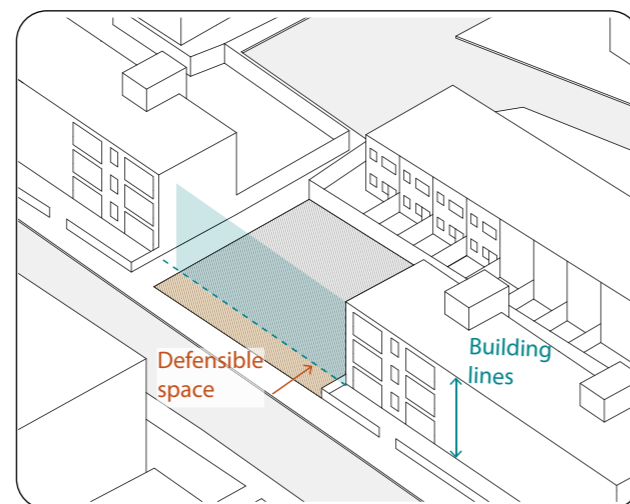
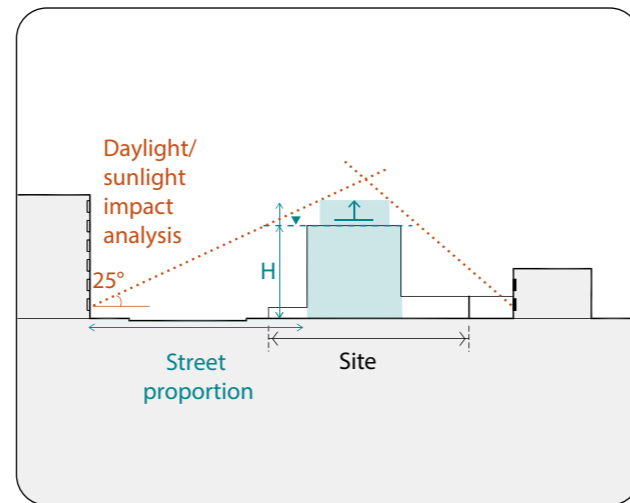

**Character-growth principles**

Suitable for: Reinforcement Mediation

**Footprint & site layout**

- Where there is no consistent building lines, developments should take the opportunity to repair the streetscape, to create a continuous pedestrian frontage and to avoid left-over spaces.
- Where developments feature inner courtyards, care should be taken to ensure that these are of a high-quality if they are intended as communal amenity space.
- Any changes in pedestrian circulation should demonstrate an improvement.

**Built form**

- An area characterised by a variety of building heights may provide opportunity for additional building height.
- For larger-scale developments, any changes to the street proportion created by them need to be carefully considered both in terms of daylight/sunlight and feeling of enclosure.

**Design & appearance**

- Defensible space and landscaping should be carefully designed and integrated into the street pattern.
- If private amenity space is to be provided through balconies, they should not project over the pavement.

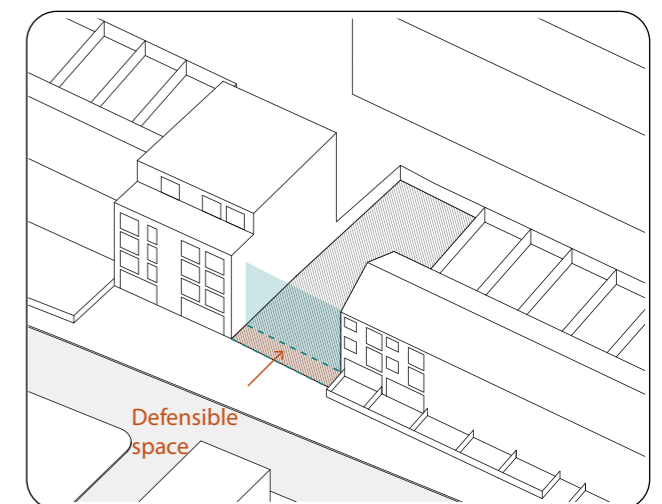
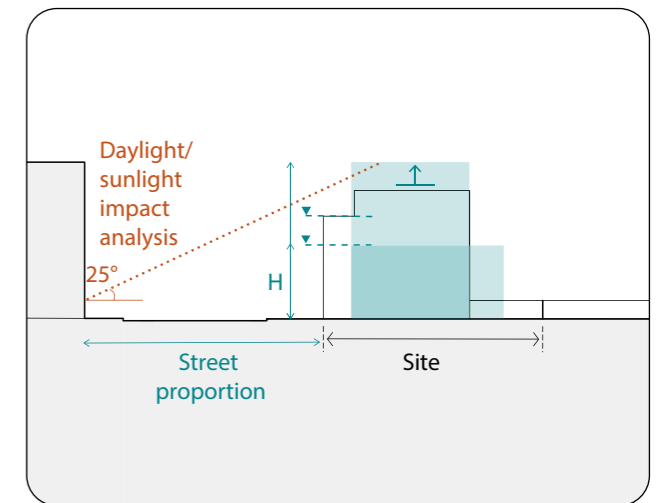
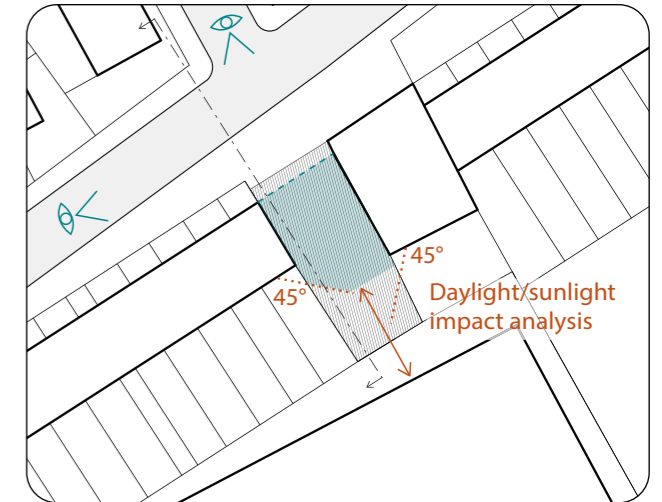

**Character-growth principles**

Suitable for: Reinforcement Mediation Reinvention



## Examples



**Vaudeville Court**  
London (Islington)  
Levitt Bernstein

Adjacent building lines are translated into the façade, frontage and height of this streetscape infill. Brick is used in a contemporary way, adding interest to the street with a clearly defined defensible space. (photo ©Tim Crocker)



**Voss Street**  
London (Tower Hamlets)  
BDA Architecture

The development sits between 2 different typologies. It follows adjacent form and building line and uses brick to integrate with the existing palette, but introduces variations in the façade design. (photo ©Ivan Jones)



**45 Prusom Street**  
London (Tower Hamlets)

The development has broken down massing into two planes to integrate into the streetscape which does not have one continuous building line. The building is also slightly set-back from the façade of the adjacent buildings to allow for a better junction detail. (photo ©Ivan Jones)

## Examples



**Edward Mills Way**  
London (Tower Hamlets)  
Stockwool

This street-fronting terrace was developed in conjunction with a mews development in a consistent architectural language, which allowed for a better integration into the streetscape. (photo ©Ivan Jones)



**Gainsford Road Housing**  
London (Waltham Forest)  
Gort Scott

Located on a residential terraced street, the flatted development has integrated the entrance to the building into the streetscape and provided a generous set-back from the pavement. (photo ©Dirk Lindner & Gort Scott)



**Home for Home RVH**  
Belfast  
McGonigle McGrath

Contemporary development stitched into the existing fabric of an historic terrace. The building does not seek to mimic the existing houses, but to build a harmonious relationship with the pre-existing ones. (photo ©McGonigle McGrath)

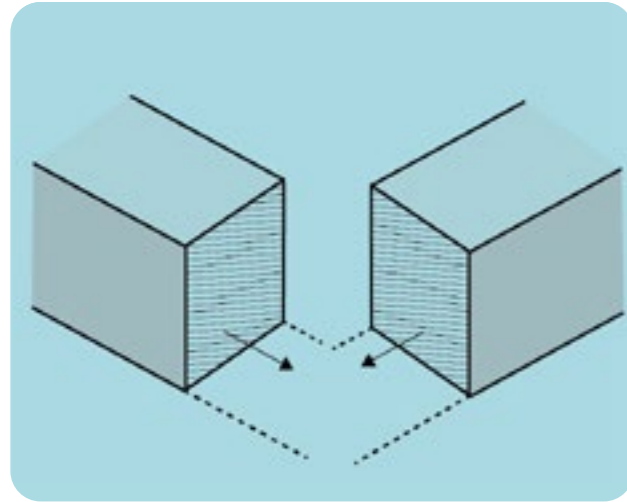
**New build****Corner infill**  
(corner infill site at node)**Description**

A site with direct access to the street and between two perpendicular walls, most likely on a junction. The adjacent buildings can be of the same or different typologies.

**Site-type specific considerations**

- It is key to consider the fact that the site has two frontages - one to either street and the new development needs to sit comfortably within both. If there is a clear hierarchy between primary and secondary streets, developments should address that through design.
- Developments may be internally linked to an existing building. This may allow for better use of space and an improved circulation and access to the existing building.
- It is likely that a building was previously located on this plot. Although knowing the previous footprint is important to understand changes to context, developments may propose a change to footprint where it is respectful of character and promotes good circulation.
- Developments should consider corner to be chamfered, set-back or rounded to increase and improve public realm.
- A corner site will need to carefully integrate servicing design as junctions will rarely allow for lay-bys.
- Existing circulation and access around the corner need to be studied and carefully addressed by the development.
- Applicants should set out the details of where the new development abuts the existing building. This junction needs to be carefully considered for materiality, durability and composition.
- Appropriate levels of privacy and daylight/sunlight must be secured to new and existing dwellings.

**New build****Corner infill**  
(corner infill site at node)**Terraces****Footprint & site layout**

- Developments should follow the established building lines of adjacent buildings on the same terrace.
- Where the corner site sits on a high-traffic junction, bedrooms and living rooms should be avoided on ground floor. This may be addressed through maisonettes.
- Where possible, entrances should be included on both frontages of the development.

**Built form**

- Where there is a strong low-rise character surrounding the site and the corner is not situated at a prominent junction, developments should follow the low-rise form to respect existing blocks.
- Additional storeys may be acceptable where a prominent development would contribute to celebrating the corner.
- Massing, roof form, eaves and parapet lines should be sensitive to adjacent buildings on the terrace.

**Design & appearance**

- Both façades should be activated by not having blank walls and prioritising prominent entrances and openings.
- Defensible space needs to be very carefully integrated into the landscape design for any ground floor dwellings
- To avoid detracting from building line, inset balconies and roof terraces may be more appropriate for private and communal amenity space provisions. Any potential privacy issues will need to be mitigated through careful design.

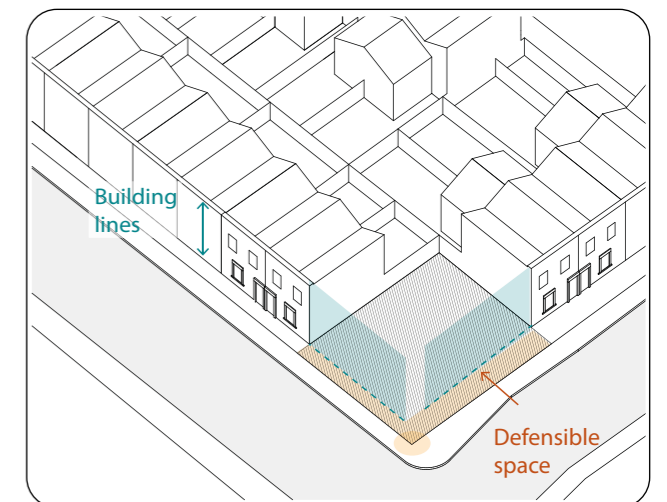
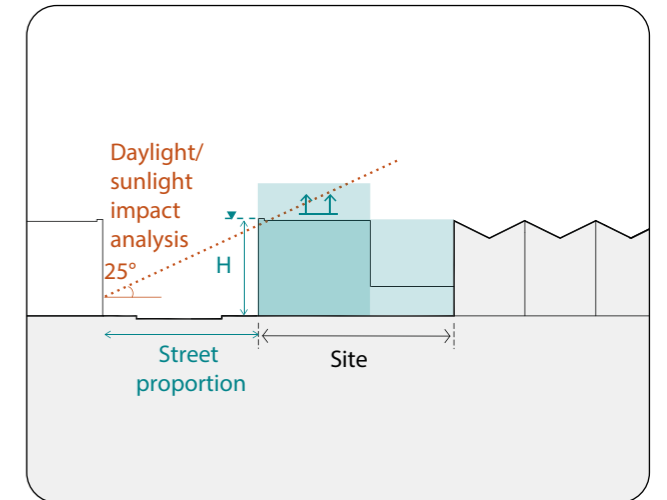
**Character-growth principles**

Suitable for: Reinforcement Mediation **Reinvention**

**New build****Corner infill**  
(corner infill site at node)

## Linear blocks

**Footprint & site layout**

- Where adjacent buildings have a deep set-back, this may be reduced at a prominent junction to optimise use of space and celebrate the corner.
- If there is an existing access or footpath through the site, these need to be maintained or re-provided, ideally with improvements, unless it is demonstrated that they are not needed.
- Where the corner site sits on a high-traffic junction, bedrooms and living rooms should be avoided on ground floor. This may be addressed through maisonettes.
- Where possible, entrances should be included on developments' two frontages.

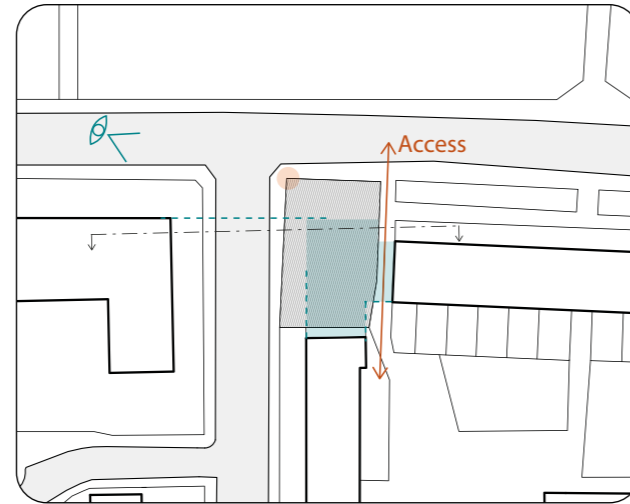
**Built form**

- Towers are scarcely present in the Central Area, and sometimes function as a local landmark. Their height should not be taken as a precedent.
- Additional storeys may be acceptable where a prominent development would contribute to celebrating the corner.

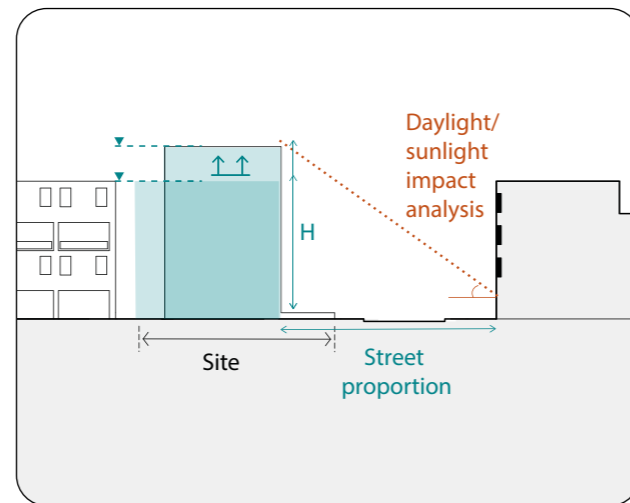
**Design & appearance**

- Both façades should be activated by not having blank walls and prioritising prominent entrances and openings.
- Defensible space should be very carefully integrated into the landscape design for any ground floor dwellings.
- Developments should plan for increased pedestrian movement around corner and to enhance wayfinding and legibility.
- If private amenity space is to be provided through balconies, they should not project over the pavement. Where the street is characterised by recessed balconies, they should be incorporated in the design.

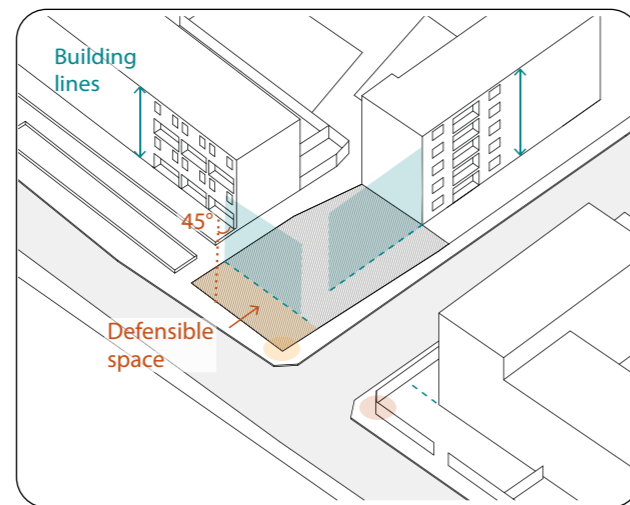
**Character-growth principles**

Suitable for: Reinforcement Mediation Reinvention

**New build****Corner infill**  
(corner infill site at node)

## Mixed typologies

**Footprint & site layout**

- Where adjacent buildings have a deep set-back, this may be reduced at a prominent junction to optimise use of space and celebrate the corner.
- If there is an existing access or footpath through the site, these need to be maintained or re-provided, ideally with improvements, unless it is demonstrated that they are not needed.
- Where the corner site sits on a high-traffic junction, bedrooms and living rooms should be avoided on ground floor. This may be addressed through maisonettes.
- Where possible, entrances should be included on developments' two frontages.

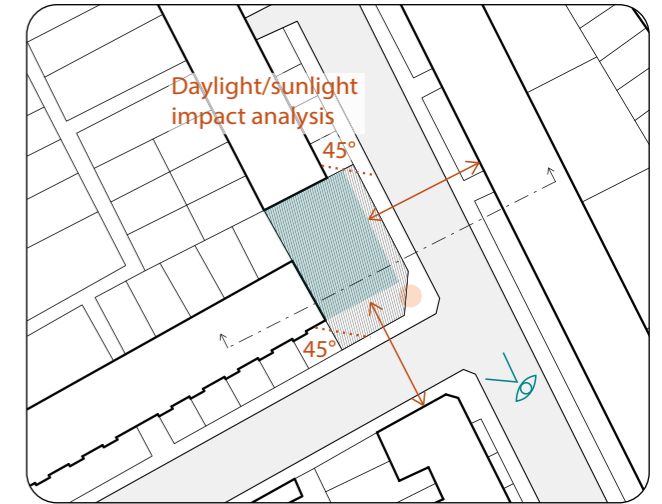
**Built form**

- Towers are scarcely present in the Central Area, and sometimes function as a local landmark. Their height should not be taken as a precedent.
- Additional storeys may be acceptable where a prominent development would contribute to celebrating the corner.

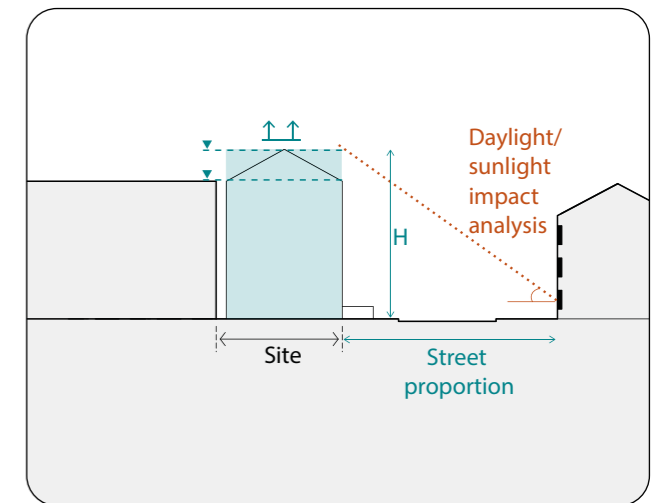
**Design & appearance**

- Both façades should be activated by not having blank walls and prioritising prominent entrances and openings.
- Defensible space should be very carefully integrated into the landscape design for any ground floor dwellings.
- Developments need to plan for increased pedestrian movement around the corner and to enhance wayfinding and legibility.
- If private amenity space is to be provided through balconies, they should not project over the pavement.

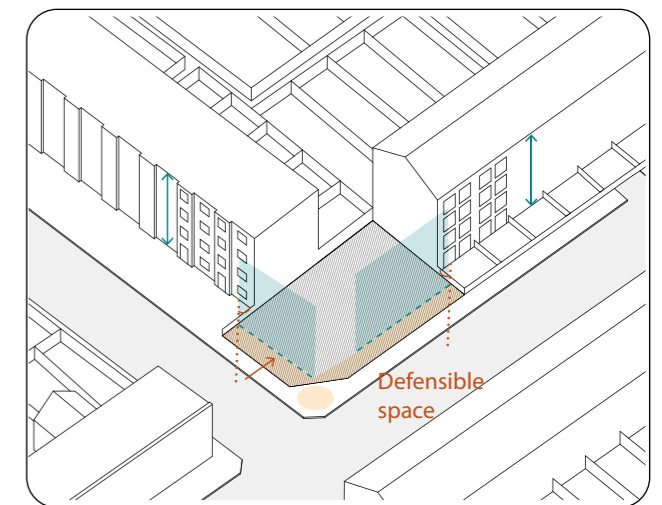
**Character-growth principles**

Suitable for: Reinforcement Mediation Reinvention

Examples



**Old Ford Road  
London (Tower Hamlets)  
pH+ Architects**

The development replaced an industrial building with the same footprint and it references the language of buildings along the canal, as well as the rhythm of the terraces of the neighbouring conservation area. (photo ©Tim Soar)



**Readmans Road  
London (Tower Hamlets)  
Heber Percy & Parker  
Architects**

The development integrated core materials from adjacent buildings (brick) into the façade. It generally follows the building lines of adjacent linear block with additional height as a corner unit. (photo ©Ivan Jones)



**Moore House  
London (Hackney)  
HYLO Architects & Matt  
White architects**

The development marks the corner with a rounded façade, allowing for better pedestrian movement and improving safety around the block. (photo ©HYLO & Matt White architects)

Examples



**Corner House  
London (Peckham)  
31/44 Architects**

The development successfully interpreted the language of adjacent terrace while following building lines and heights, but introducing new contemporary detailing to the façade and materials. (photo ©Rory Gardiner)



**Chalkhurst Court  
London (Croydon)  
Tate Harmer**

The development introduced additional height and massing into a terraced street, but carefully broke down massing with the use of 2 contrasting materials and set-backs. (photo ©Tate Harmer)



**Shoreditch Triptyche  
London (Hackney)  
Chris Dyson Architects**

This development has a primary and secondary building frontage, each relating to the streetscape it sits within. Fenestration rhythms and building heights follow those of the adjacent terraces. (photo ©Peter Landers)

**New build****Block extension**

(one blank gable to build off from)

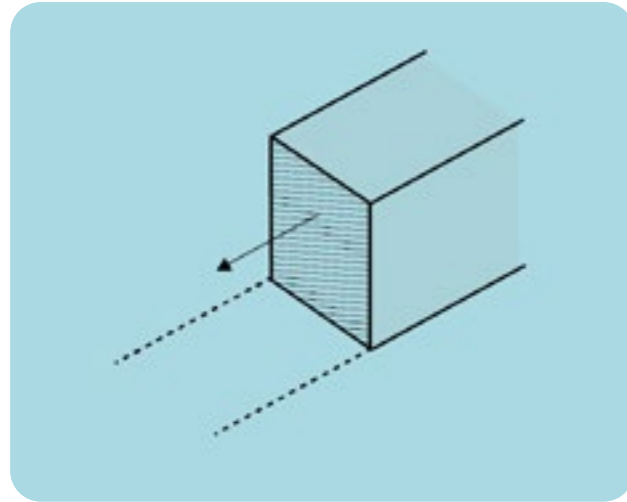
**Description**

A site that can be developed straight off a blank wall of an adjacent building. The blank wall will most likely be the end of a terrace or the side elevation of a linear block.

**Site-type specific considerations**

- Developments may be internally linked to an existing building. This may allow for better use of space and an improved circulation and access to the existing building.
- Where the block extension is on a junction, developments should activate both façades to enhance passive surveillance and optimise the use of natural light.
- Developments will not be considered appropriate where adjacent building is harmed by a side addition. For example, it will generally be resisted where the development would be adjacent to a mansion block which has a carefully composed symmetry.
- Applicants should set out the details of where the new development abuts the existing building. This junction needs to be carefully considered for materiality, durability and composition.
- Appropriate levels of privacy and daylight/sunlight must be secured to new and existing dwellings.

**New build****Block extension**

(one blank gable to build off from)

**Terraces****Footprint & site layout**

- Developments should follow the established front and rear building lines of adjacent buildings on the same terrace.

**Built form**

- A key characteristic of terraced streets is their consistent eaves and roofline. This consistency presents opportunities for developments to promote continuity. Where there is consistency, the development's massing, eaves line, parapet line and roof form should follow those of adjacent buildings on the terrace. However, where site is on a corner, additional storeys may be acceptable where a prominent development would contribute to celebrating the corner.

**Design & appearance**

- Where new building façades are proposed within an existing terrace, the design of these should respect the vertical rhythm and proportions of neighbouring buildings
- Where replicating architectural elements (such as single-glazed windows, accessibility barriers) would be against current regulations, applicants are encouraged to suggest suitable alternatives that are in line with the development's design vision.
- To avoid detracting from building line, inset balconies and rear roof terraces may be more appropriate for private and communal amenity space. Any potential privacy issues will need to be mitigated through careful design.

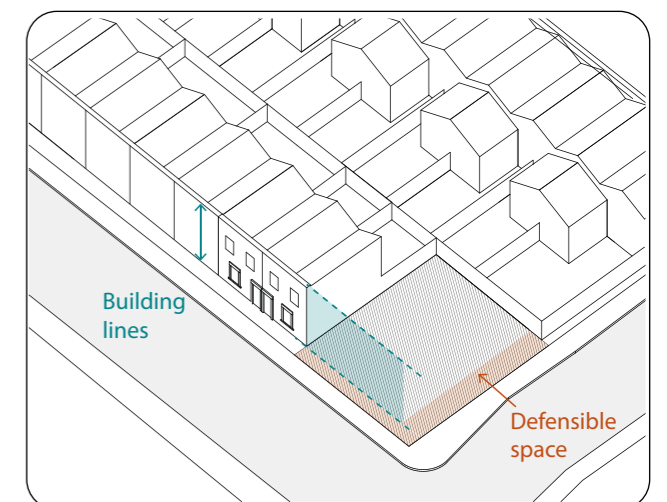
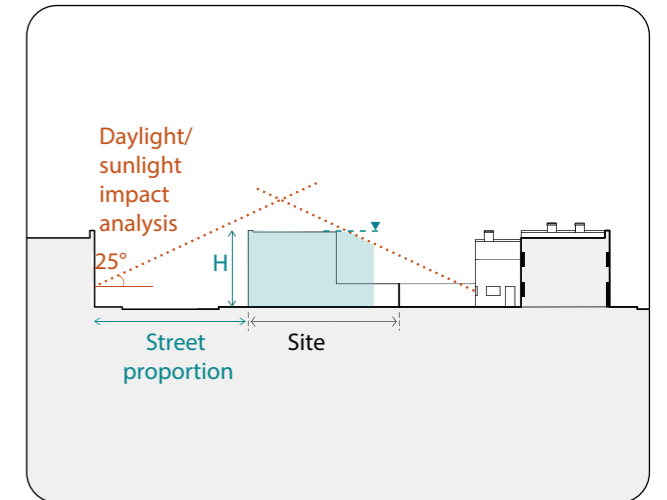
**Character-growth principles**

Suitable for:

Reinforcement

Mediation

**New build**

**Block extension**  
(one blank gable to build off from)

**Linear blocks**

**Footprint & site layout**

- Developments should follow the established building lines of adjacent linear blocks where this is consistent.
- Where adjacent building has a deep set-back, this set-back may be reduced at a prominent junction to optimise use of space and celebrate the corner.

**Built form**

- Towers are scarcely present in the Central Area, and sometimes function as a local landmark. Their height should not be taken as a precedent.
- If site is on a corner, additional storeys may be acceptable where a prominent development would contribute to celebrating the corner.

**Design & appearance**

- Defensible space and landscaping needs to be carefully designed and integrated into the street pattern.
- If private amenity space is to be provided through balconies, they should not project over the pavement. Where the street is characterised by recessed balconies, they should be incorporated in the design.

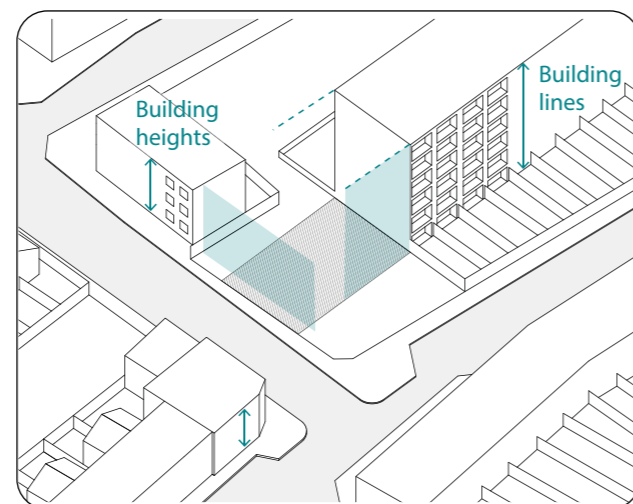
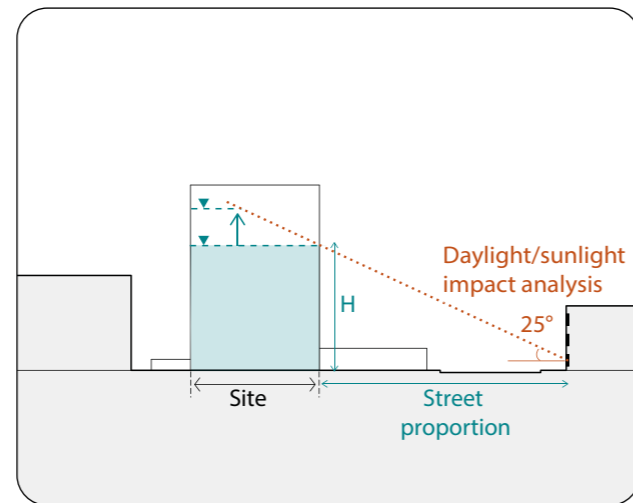
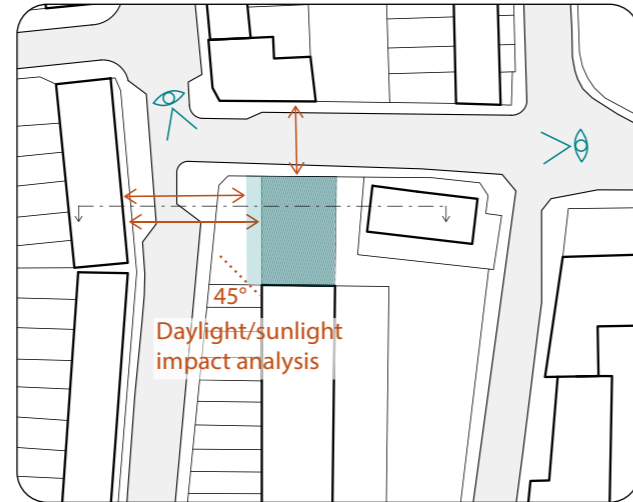

**Character-growth principles**

Suitable for: Reinforcement Mediation

**New build**

**Block extension**  
(one blank gable to build off from)

**Examples**



**Salmen House**  
London (Newham)  
Office S&M

The development follows massing, building line and roof form of adjacent terrace and integrates playful use of materials and fenestration into a terrace of mixed materiality. (photo ©French + Tye)



**Bethnal Green**  
Mission Church  
London (Tower Hamlets)  
Gatti Routh  
Rhodes Architects

The success of this development is largely due to the high-quality choice of materials and attention to detailing. (photo ©Jack Hobhouse.)



**52 Tredgar Square**  
London (Tower Hamlets)

The newer addition fits in seamlessly with the existing terrace and is only identifiable by minor details and a slightly different tone of brick. The new brick still includes the same level of colour variation and texture as the adjacent buildings on the terrace. (photo ©Ivan Jones)

## Examples



**Cresset Street**  
London (Lambeth)  
Tom Smith and Kathryn Larriva

A clearly expressed side extension with new use of materials. Window proportions relate to the host building and the end gable is of a matching brick to the existing unit.



**66 Brick Lane**  
London (Tower Hamlets)

The corner unit follows proportions, building lines, materials and massing of adjacent buildings on the terrace, but it is clearly distinguishable as a contemporary addition with its single plane windows. A more playful façade composition is expressed on its secondary elevation. (photo ©Ivan Jones)

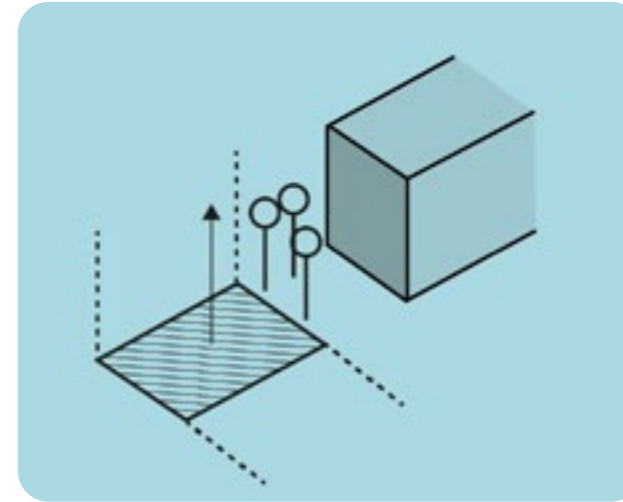
**Description**

A site located in a side garden or a backgarden.

**Site-type specific considerations**

- Whilst there are limited opportunities for garden infill in the Central Area, for the sites that are available, the size of the garden must be adequate to receive a new building without compromising access, safety and legibility for new and existing dwellings.
- Minor developments should seek to achieve the London Plan principle of no net loss of overall green cover. Major developments should contribute to the greening of London by following the London Plan's Urban Greening Factor. Green cover may be provided by returning hard standing to green space, tree planting, the installation of green roofs and green walls, or the provision of landscaping that facilitates sustainable urban drainage.
- Appropriate levels of privacy and daylight/sunlight must be secured to new and existing dwellings.
- In order to maintain good levels of daylight/sunlight and outlook, developments should seek to implement rooflights, oblique windows and carefully-placed windows that respond to site constraints.

**Footprint & site layout**

- Developments should promote a pedestrian-friendly street frontage. They may create new interest along the streetscape or closely follow adjacent buildings.
- The primary frontage should be street-facing, including access, outlook and passive surveillance.
- Often gaps between built form are an important part of the townscape, specially in terraced streets. Developments' massing and footprint should respect this.

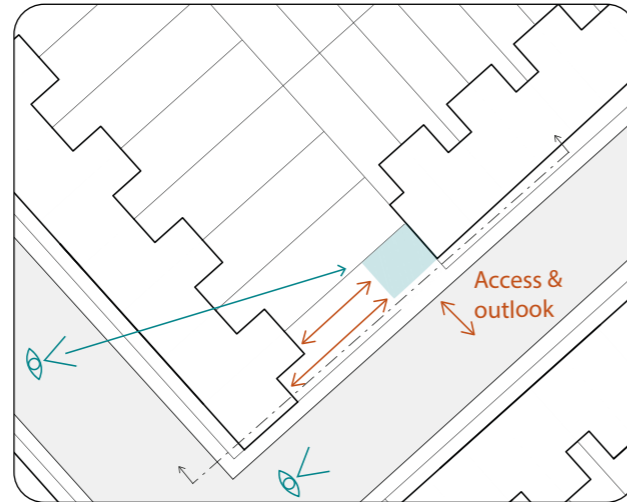
**Built form**

- The massing and roof form including any set-backs should be sensitive to the urban character of the streetscape, particularly if they do not follow adjacent building lines.
- Developments should be of an equal or smaller scale to buildings on opposite side of garden.

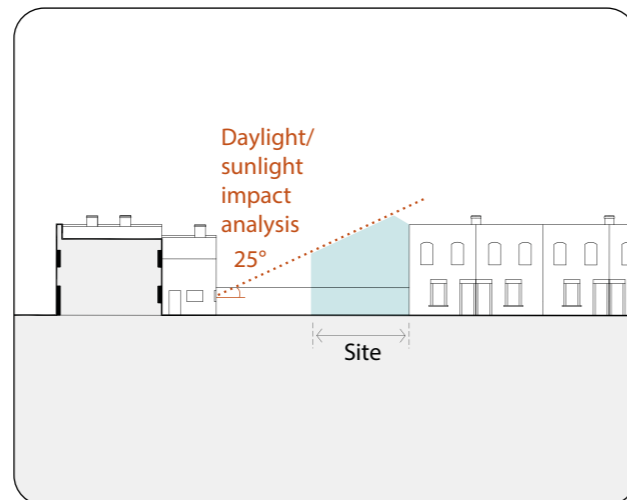
**Design & appearance**

- Developments may suggest an innovative design that differs from the streetscape in order to address constraints.
- Defensible space, internal layouts and landscaping should be carefully designed to provide adequate privacy in relation to surrounding buildings and gardens.
- The provision of amenity space through internal courtyards and rear terraces is encouraged. If private amenity space is to be provided through balconies, these will need to be carefully designed to be integrated into the streetscape and to avoid unacceptable intervisibility.

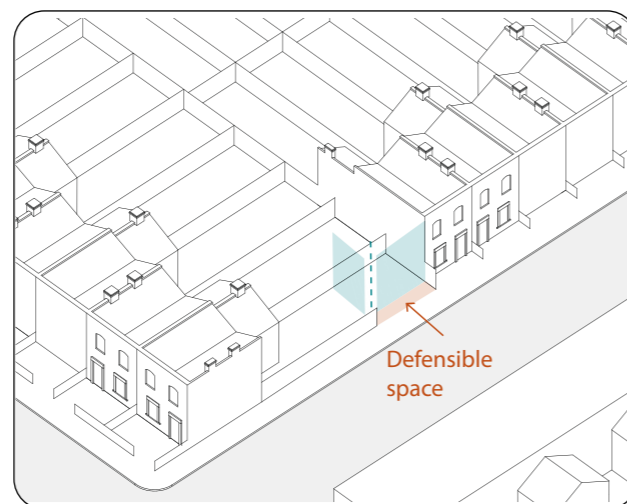
**Character-growth principles**

Suitable for:

Mediation

Reinvention

**Footprint & site layout**

- Developments should create a pedestrian-friendly street frontage.
- The primary frontage should be street-facing, including access and passive surveillance.

**Built form**

- The massing and roof form including any set-backs should be sensitive not only to the urban character of the surrounding streets, but also to buildings on opposite side of garden.

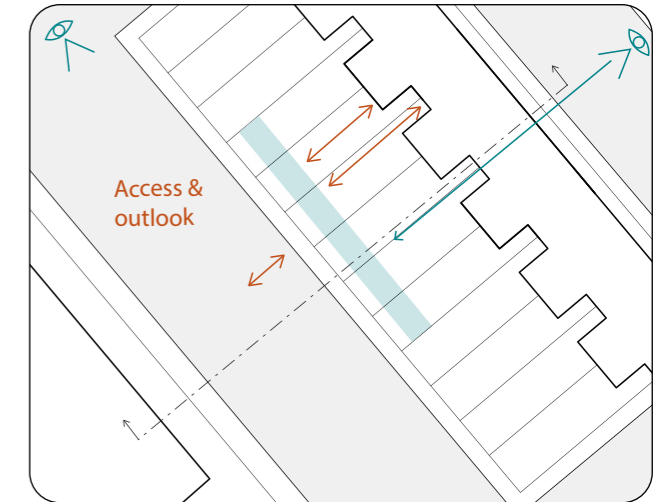
**Design & appearance**

- Developments may introduce a new street frontage and/or pattern and therefore bring forward more innovative design.
- Defensible space, internal layouts and landscaping should be carefully designed to provide adequate privacy in relation to surrounding buildings and backgardens.
- The provision of amenity space through internal courtyards and rear terraces is encouraged. If private amenity space is to be provided through balconies, these will need to be carefully designed to be integrated into the streetscape and to avoid unacceptable intervisibility.

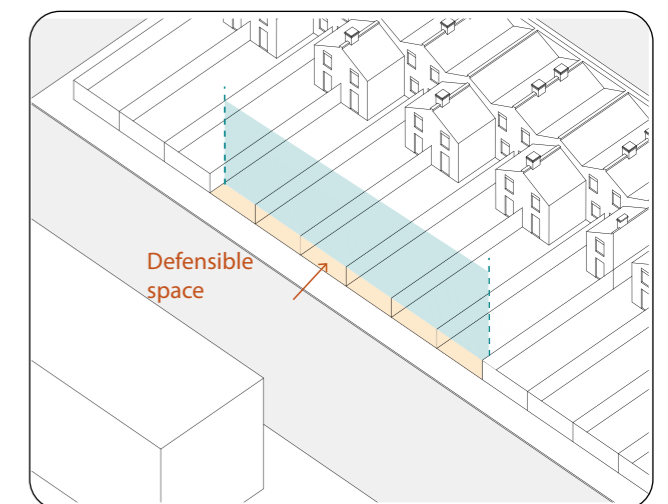
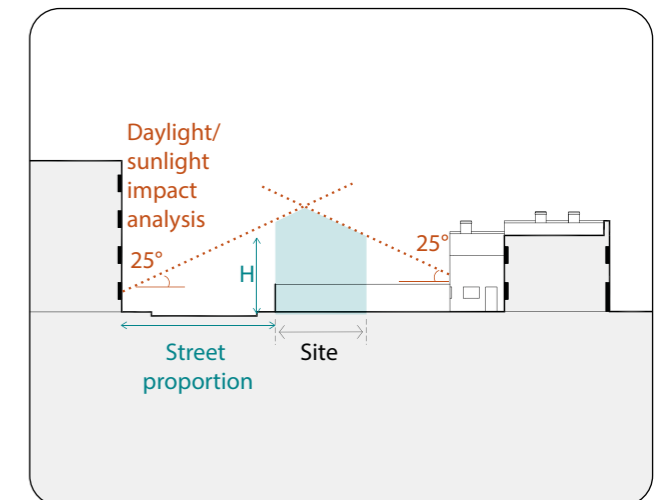
**Character-growth principles**

Suitable for:

Mediation

Reinvention



## Examples



**Small Black Home**  
**London (Haringey)**  
**Russell Jones**

The existing Victorian outbuilding was retained and remains legible through contrasting material used for the new building. To gain good natural light, a clerestory window ribbon is integrated into the roofline. (photo ©Rory Gardiner)



**Wapping Pierhead**  
**London (Tower Hamlets)**  
**Chris Dyson Architects**

Removal of a structurally unsound pre-war side extension made room for a more generous wing. The design responds to the architecture of the house through reinterpretation rather than imitation. (photo ©Peter Landers)



**Red-Brick House**  
**London (Southwark)**  
**31/44 Architects**

The house shares the visual language of the adjacent Victorian terrace, but it is designed in a contemporary way. Two internal courtyards alongside the boundary wall at the rear and side of the property maximise the use of natural light. (photo ©Rory Gardiner)

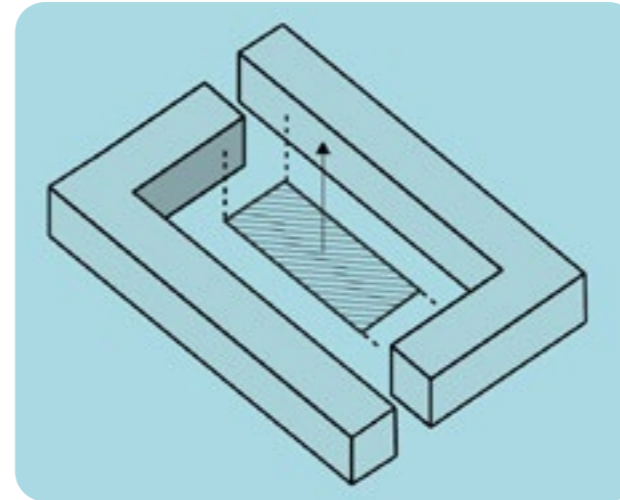
**Description**

A site with no direct access to the street. The development will most likely be a terrace, mews development or small cluster of houses.

**Site-type specific considerations**

- Whilst there are limited opportunities for backland development in the Central Area, for the sites that are available, the size of the backland must be adequate to receive a new building without compromising amenity, access, safety and legibility for new and existing dwellings.
- Minor developments should seek to achieve the London Plan's principle of no net loss of overall green cover. Major developments should contribute to the greening of London by following the London Plan's Urban Greening Factor. Green cover may be provided by returning hard standing to green space, tree planting, the installation of green roofs and green walls, or the provision of landscaping that facilitates sustainable urban drainage.
- Appropriate levels of privacy and daylight/sunlight must be secured to new and existing dwellings.
- In order to maintain good levels of daylight/sunlight, developments should seek to implement rooflights, oblique windows and carefully-placed windows that respond to site constraints.

**New build**

**Backland**  
(no current access to street)

**Footprint & site layout**

- Developments should create a pedestrian-friendly frontage and access.
- Developments should set out a clear access and management strategy (i.e. fire safety, servicing, circulation) for the site as this is likely to determine the potential capacity. Access can be provided through existing gaps in the surrounding built form or by creating new points of entrance in the urban block that are carefully integrated into streetscape.
- Orientation of habitable rooms and windows should be carefully designed to guarantee privacy and appropriate daylight/sunlight levels to new and existing dwellings.
- Developments should promote ground floor front-door access.

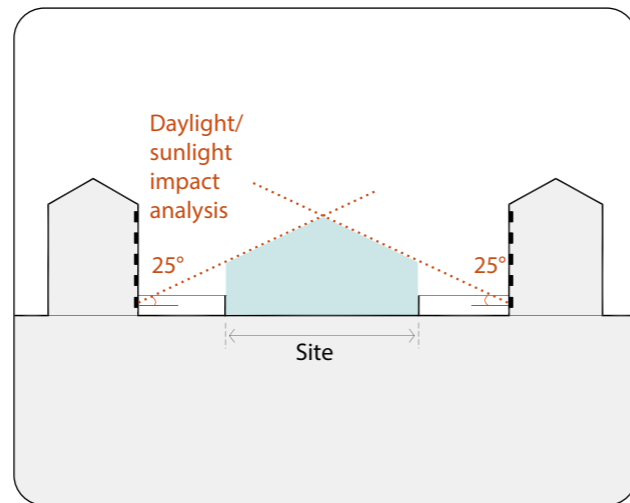

**Built form**

- Scale and height should be of an equal or smaller scale to existing buildings. They should also be based on separation distances to existing buildings and maintaining appropriate levels of daylight/sunlight and privacy.

**Design & appearance**

- If parts of developments are visible from the street, a detailed analysis of impacts on townscape and views should be done to ensure the design promotes a positive integration with surrounding buildings.
- Developments should seek to maintain instances of long views between buildings and backgardens.
- Amenity space is likely to be more appropriate through internal courtyards and inward-facing balconies.

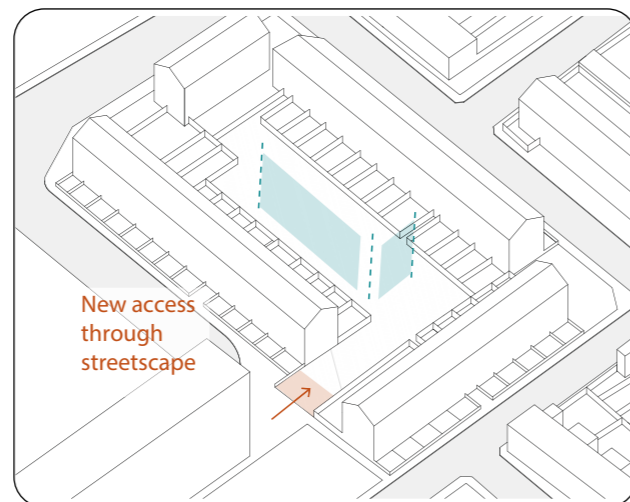

**Character-growth principles**

Suitable for: **Mediation** **Reinvention**

**New build**

**Backland**  
(no current access to street)

**Examples**



**Moray Mews**  
**London (Islington)**  
**Peter Barber Architects**

New mews development where each house is entered through a private courtyard which provides good defensible space for the residents. Oriel windows allow for added interest and good use of light. (photo ©Morley von Sternberg)



**Otts Yard**  
**London (Camden)**  
**vPPR Architects**

This backland development place extra care into how it would look like from above, creating an interesting landscaped green roof for the surrounding units to look at. (photo ©Helene Binet)



**Moore Park Road**  
**London (Hammersmith and Fulham)**  
**Stephen Taylor Architects**

Four carefully-orientated houses within a backland infill plot. Each house faces inwards into a private courtyard space. Materials, massing and roof form reflect the surrounding housing. (photo ©David Grandorge)

## Examples



**Beveridge Mews**  
London (Tower Hamlets)  
Peter Barber Architects

Estate infill replacing garage spaces and creating new family-sized units. The stepped profile allows for good daylight/sunlight and privacy levels, and integrated external amenity space. (photo ©Morley von Sternberg)



**Tredegar Square**  
London (Tower Hamlets)  
Jonathan Freegard Architects

Eight new units on the site of a former warehouse make best use of the existing narrow site. The scheme includes greywater recycling, lightweight construction and PV panels. (photo ©JF Architects)



**Tin House**  
London (Wandsworth)  
Henning Stummel

This backland inward-looking single-storey design is set around a courtyard. The materials and form of the design sit in contrast with the context but create a cohesive design for the new separate but conjoined units. (photo ©Henning Stummel)

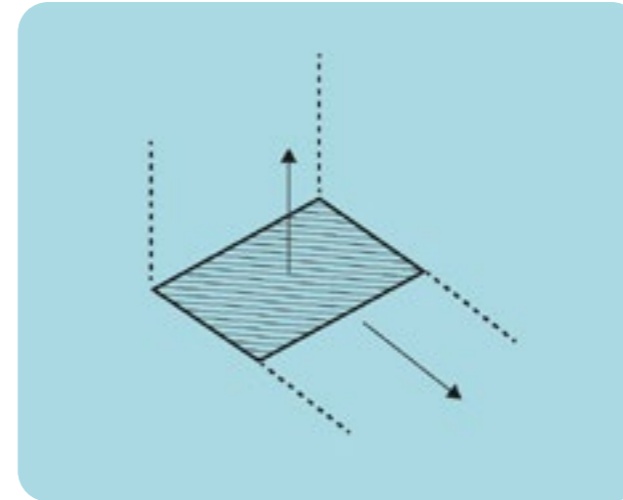
**Description**

A site that is not immediately adjacent to any buildings.

**Site-type specific considerations**

- As the site is not immediately adjacent to any buildings, applicants should identify the building types of the nearby surrounding buildings and refer to their descriptions in Chapter 4 - Central Area housing typologies to develop a design response that is appropriate to context.
- The development's frontage should be determined by the surrounding buildings. If there is none, there is an opportunity for more unique and innovative designs to be proposed.
- Developments should allow for future growth surrounding the plot (i.e. they should consider including blank façades where adjacent plots might be developed). They should not borrow access to daylight/sunlight from neighbouring undeveloped plots.
- Minor developments should seek to achieve the London Plan's principle of no net loss of overall green cover. Major developments should contribute to the greening of London by following

the London Plan's Urban Greening Factor. Green cover may be provided by returning hard standing to green space, tree planting, the installation of green roofs and green walls, or the provision of landscaping that facilitates sustainable urban drainage.

- The street width should generally be no less than the height of the buildings facing it. This distance could be reduced if innovative design responses can demonstrate that good levels of daylight/sunlight and privacy can be achieved.
- Towers are scarcely present in the Central Area, and sometimes function as a local landmark. Their height should not be taken as a precedent
- Appropriate levels of privacy and daylight/sunlight must be secured to new and existing dwellings.

**Character-growth principles**

Suitable for: **Reinvention**

## Examples



**Southern Grove  
London (Tower Hamlets)  
Architecture PLB**

This development sits next to a converted Victorian warehouse. The open spaces that are framed by it are crucial to the placement of the buildings and design of the public realm. (image ©Keyframe Visuals.)



**Armagh road  
London (Tower Hamlets)  
PRP Architects**

This estate infill responds, on one hand, to the rhythm of the terraces, but also marks the corner as a transitional point between different building heights. (photo ©Ivan Jones)

## Examples



**Mint Street  
London (Tower Hamlets)  
Pitman Tozer Architects  
for Peabody**

Maisonettes are integrated on ground floor as ground floor flats would be inappropriate due to site constraints. (photo ©Kilian O'Sullivan)



**Marmalade Lane  
Cambridge  
Town & Mole Architects**

Detached plots can allow designers to rethink the building frontage and public/private spaces in and around the buildings, such as this co-housing scheme. (photo ©Jim Stephenson & Town)

## Extensions

### Roof extensions (added to host building)

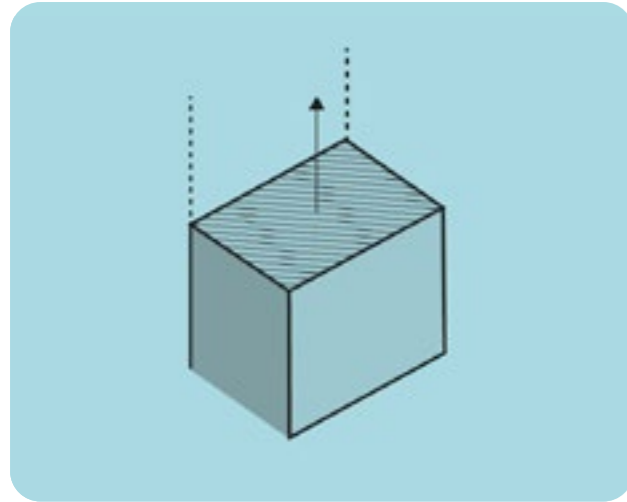

#### Description

Roof extensions can be added to existing buildings to increase space to existing dwellings or to create new dwellings.

#### Site-type specific considerations

- If neighbouring properties are seeking extensions, applicants are encouraged to submit these as a mirror proposals. There may be more scope for change when this is done comprehensively.
- Internal circulation needs to be carefully considered at early design stage, particularly if extensions create new dwellings.
- Materials do not need to match those of host building; however it is key that they present a positive integration with the existing ones. If clearly distinguishable materials are used, developments should consider if these could also be introduced in the host building where improvement works are required to existing fabric.
- Applicants should set out the details of where the new development abuts the existing building. This junction needs to be carefully considered for materiality, durability and composition. Elevation drawings showing materials and shadows will also be key to discuss the development's design.
- Appropriate levels of privacy and daylight/sunlight must be secured to new and existing dwellings.

- In order to maintain good levels of daylight/sunlight, developments should seek to implement rooflights, oblique windows and carefully-placed windows that respond to site constraints.
- Most Victorian and Georgian terraces within the Central Area are located in conservation areas. Generally, planning permission to roof extensions will not be granted due to the potential for harm to the historic environment, with the exception of some conservation areas where Conservation Area Character Appraisals and Management Plans set clear design requirements which extensions need to comply with to be considered acceptable. This section does not cover these circumstances. If a proposal falls under these described conditions, applicants should refer to the appropriate Conservation Area Character Appraisals and Management Plans.

## Extensions

### Roof extensions (added to host building)

### High street

#### Footprint & site layout

- If adjacent buildings have defined frontage lines, these should be followed. Extensions should not project beyond the rear line of the building.
- Developments should provide well-defined and separate entrances to commercial and residential spaces.
- Bedrooms should preferably face away from the street to allow for adequate privacy and noise mitigation.

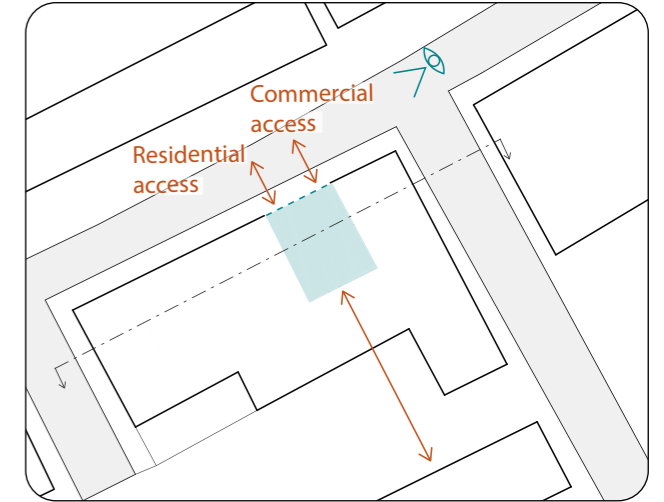

#### Built form

- Extensions should be of a smaller scale than the existing building.
- If site is on a corner there may be some scope for taller heights than adjacent buildings but the street proportion created by developments needs to be carefully considered both in terms of daylight/sunlight and feeling of enclosure. Set-backs may help to break massing but these need to be carefully designed so as not to compromise existing building lines.

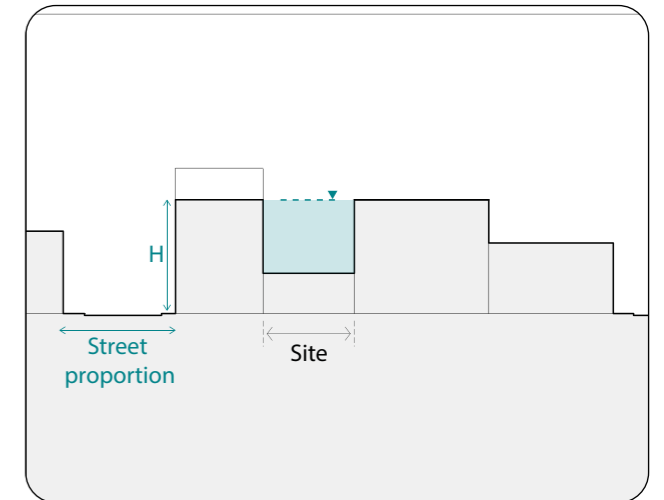

#### Design & appearance

- Many high streets display a regular rhythm which should be reflected in developments' façade and composition.
- Where there is a variety of building types, developments should follow the design and proportions of the host building to avoid creating a fragmented streetscape
- Where vehicular traffic/footfall are high, private amenity space is likely to be more appropriate on the rear elevation. If street-facing balconies are proposed, they should not project over the pavement. Inset balconies allow for private amenity space to be integrated without compromising building lines.

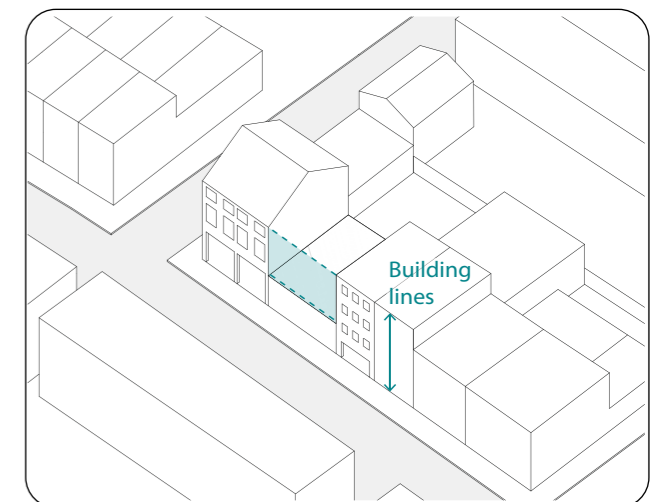

#### Character-growth principles

Suitable for: Reinforcement Mediation Reinvention

## Extensions

### Roof extensions (added to host building)

### Linear blocks

#### Footprint & site layout

- Developments should follow existing footprint but set-backs may be needed to avoid unacceptable overshadowing.
- Where circulation is done through deck-access and living rooms and/or bedrooms are proposed to face onto it, applicants will need to demonstrate that there is minimal footfall, the deck-access width allows for a buffer between windows and circulation and/or there are other privacy and noise mitigation measures.
- Developments should provide adequate access and comply with appropriate number of flats being served by cores.
- Developments should seek to improve communal areas and access to existing residential units. In some cases, a side extension or alterations to existing cores could allow for improved circulation and more comprehensive redevelopments.

#### Built form

- Extensions should reference key architectural elements from the host building, such as vertical/horizontal rhythms, materiality. Small set-backs may help to break massing but they need to be carefully designed so as not to compromise existing building lines.

#### Design & appearance

- If the host building has overhanging balconies, these may be incorporated, provided acceptable levels of daylight/sunlight and outlook are achieved.
- Where the host building has no overhanging balconies, new ones should not project over the building line. Inset balconies allow for private amenity space to be integrated without compromising building lines.

#### Character-growth principles

Suitable for: Reinforcement

Mediation

Reinvention

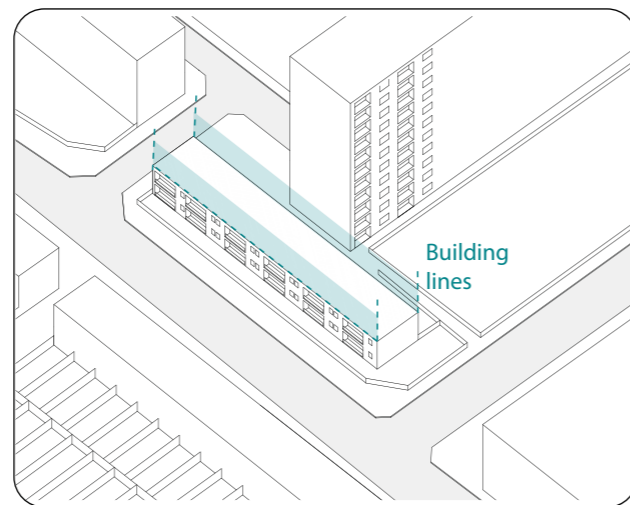
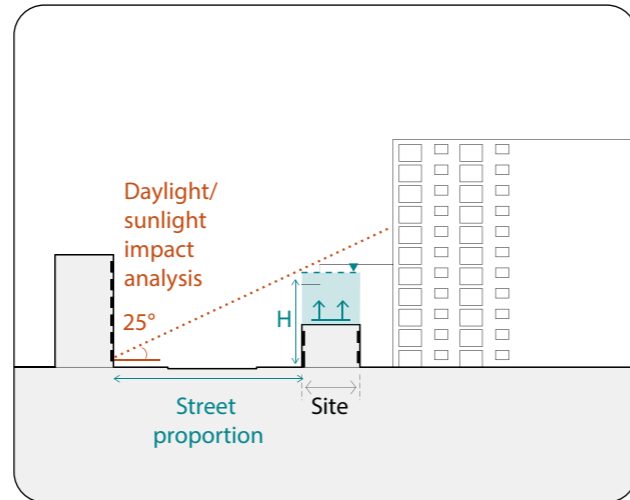
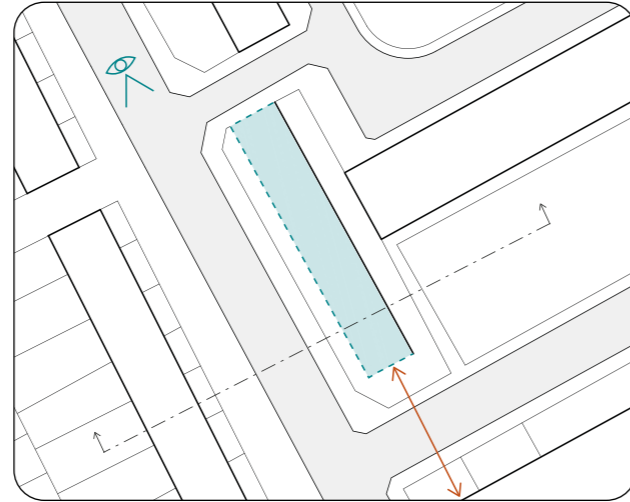

## Extensions

### Roof extensions (added to host building)

#### Examples



#### Reardon Path London (Tower Hamlets) Proctor Matthews

The 2-storey addition to a single-storey base displays good use of materials. Slate and timber cladding complement the brick and have been carefully detailed with aluminium drips and sliding timber shutters to the side. (photo ©Ivan Jones)



#### Buttermere House London (Tower Hamlets) Ian Ritchie Architects and VR architects

The 2-storey roof extension continues the expression of vertical and horizontal elements found in the host building while introducing a new material to express the additional storeys. (image ©Glass Canvas & Ian Ritchie Architects + VRA)



#### Damien Court London (Tower Hamlets) Rivington Street Studio

The rooftop development on a 4-storey residential block reinforces the form of the host building. The development also included improvements to existing communal areas. (photo ©Rivington Street Studio)

## Extensions

### Rear extensions (added to host building)

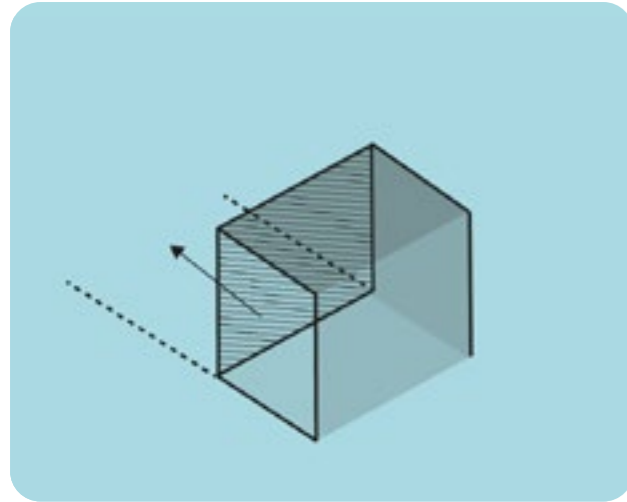

#### Description

Rear extensions can be added to existing buildings to increase space to existing dwellings.

#### Site-type specific considerations

- Developments should carefully address existing buildings.
- Materials do not need to match those of host building; however it is key that they present a positive integration with the existing ones.
- Applicants should set out the details of where the new development abuts the existing building. This junction needs to be carefully considered for materiality, durability and composition.
- Extensions should seek to achieve the London Plan's principle of no net loss of overall green cover through tree planting, the installation of green roofs and green walls, or the provision of landscaping that facilitates sustainable urban drainage.
- Appropriate levels of privacy and daylight/sunlight must be secured to new and existing dwellings.
- In order to maintain good levels of daylight/sunlight, developments should seek to implement rooflights, oblique windows and carefully-placed windows that respond to site constraints.
- For extensions proposed to terraces within conservation areas, applicants should be aware that they may be deemed to affect the character and setting of the conservation area even

if they are not visible from the street.

Applicants should refer to the appropriate Conservation Area Character Appraisals and Management Plans.

## Extensions

### Rear extensions (added to host building)

#### Footprint & site layout

- Developments should create a positive relationship with surrounding buildings and backgardens.
- Developments should not hinder similar new extensions for neighbouring properties.
- New windows should respect neighbours privacy; when facing onto neighbouring properties, alternative solutions such as rooflights, high level windows, frosted glass and angled views are encouraged.

#### Built form

- Extensions should be of a scale not greater than the host building's envelope.
- Applicants are encouraged to study the back line of the terrace to establish what the most suitable scale and form of extension for the host building in relation to neighbouring buildings might be.
- Developments should respect terrace's eaves lines if these are consistent.

#### Design & appearance

- Extensions should relate to the rhythm of the existing façade including scale, fenestration and detailing.
- Developments should seek innovative design solutions to breaking of massing and rooflines, particularly if extensions have more than one storey.

#### Character-growth principles

Suitable for: Reinforcement

Mediation

## Terraces

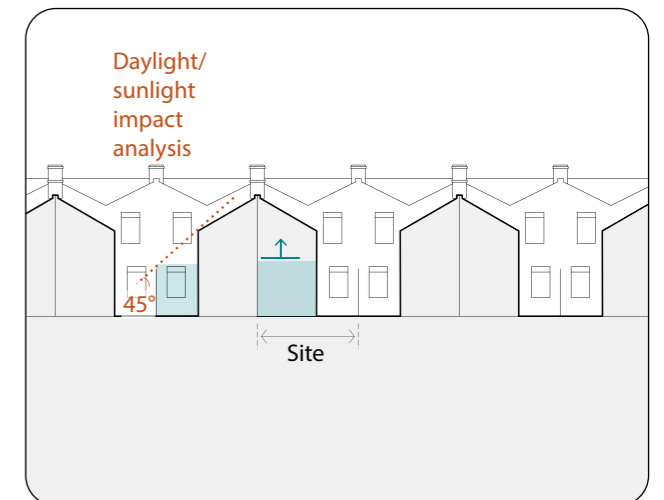
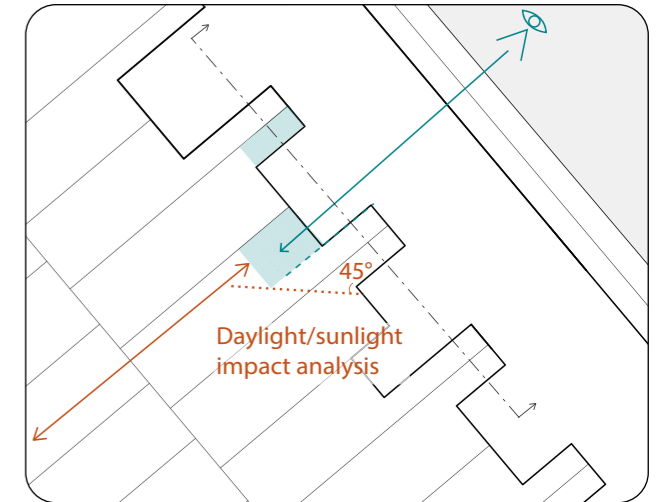

## Examples

**Kemplay Road  
Hampstead (Camden)  
Chris Dyson Architects**

This extension complements the rear façade. The form and size is proportional to the building and modern features are introduced in the details through double-height window and delicate new steps and railings. (photo ©Peter Landers)

**The Timber Frame  
Extension  
London (Camden)  
YARD Architects**

This small side return extension to a Victorian terraced house sits modestly between the boundary wall and the host building as an expressed contemporary addition. (photo ©YARD Architects)

**Tsubo Niwa House  
London (Hackney)  
Fraher & Findlay**

This modern single-storey rear and side infill extension sits in contrast to the host building using high-quality, contemporary materials. (photo ©Adam Scott)

## Footprint &amp; site layout

- Early consultation with TfL/Network Rail is required.
- Developments should address noise and vibration impact on and from the railway.
- Developments should include landscaped buffer space between rail and residential frontages. Water and/or green features should be considered to humanise the entrances.
- Access for maintenance to the railway or maintenance for the development should be accounted for at early design stages.
- Site may allow for increases in massing and height if near a transport node but regard to surrounding character and height is still paramount.
- Minimum required distances should be maintained between development and railway. This is typically between 3-5m and varies depending on the rail provider (Network Rail, TfL, DLR).

## Design &amp; appearance

- Developments are encouraged to design openings away from railway infrastructure. Any openable windows should not present a risk to the rails and the window openings should preferably be at high level.
- Habitable rooms facing towards railways should ideally be dual-aspect to provide natural ventilation and opportunity for insertion of balconies facing away from railway. Use of winter gardens should not be the default design resolution for single-aspect habitable rooms facing a railway.
- Noise, pollution and vibration mitigation measures will be required for properties around rail infrastructure such as triple-glazed windows and attenuated openings.
- Storeys set at the same level as railway and/or railway arches should accommodate non-residential uses on railway side.

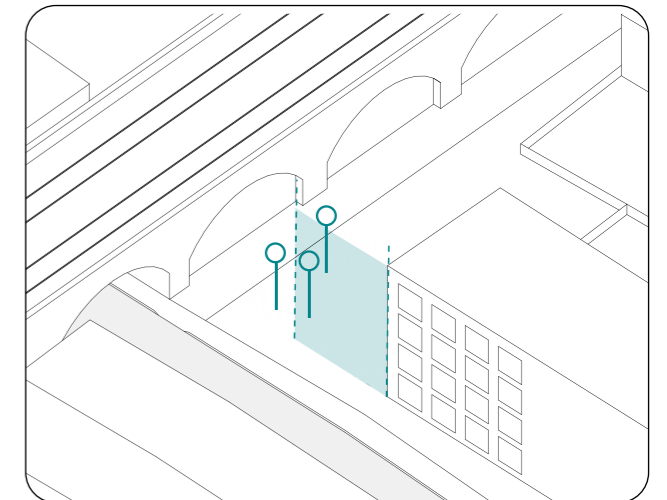
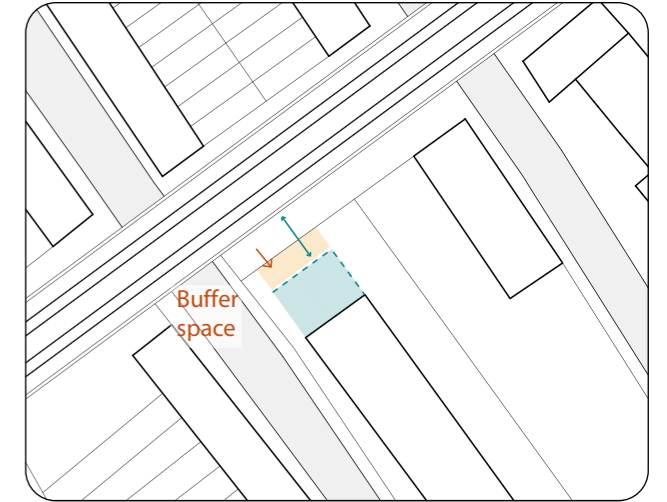



**Footprint & site layout**

- Where appropriate in relation to existing building lines, developments should step back from the edge of the pavement to secure an enhanced public realm.
- Developments should include landscaped buffer space between road and residential frontages. Water and/or green features should be considered to humanise the entrances.
- Bedrooms and living rooms should be avoided on ground floor. This may be addressed through maisonettes.
- Waste collection and servicing of development should be agreed with Highways at an early design stage.
- Site may allow for increases in massing and height if near a transport node but regard to surrounding character and height is still paramount.

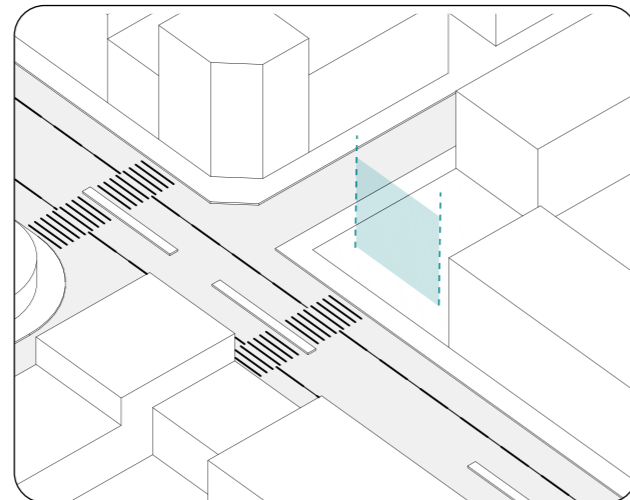
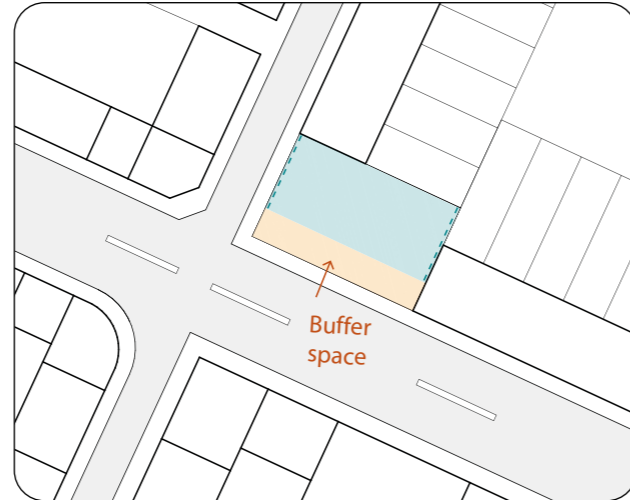

**Design & appearance**

- Residential units should include openable windows that do not face onto the high-traffic road.
- Balconies and private amenity space should preferably face away from the high-traffic road.
- Developments should demonstrate how noise, pollution and vibration impacts from the road are going to be addressed at early design stages.
- Inner courtyard should be considered to create a quieter outdoor micro climate for residents.

**Footprint & site layout**

- Where possible, footprint and massing should allow for views towards the waterfront from public realm.
- Developments should seek to improve public circulation and access to the waterfront, including supporting a continuation of the Thames Path, to promote active travel and allow local communities to access the health and well-being opportunities associated with water infrastructure.
- Green spaces along the waterfront are rare, these must be protected or enhanced and any new public spaces will be encouraged.

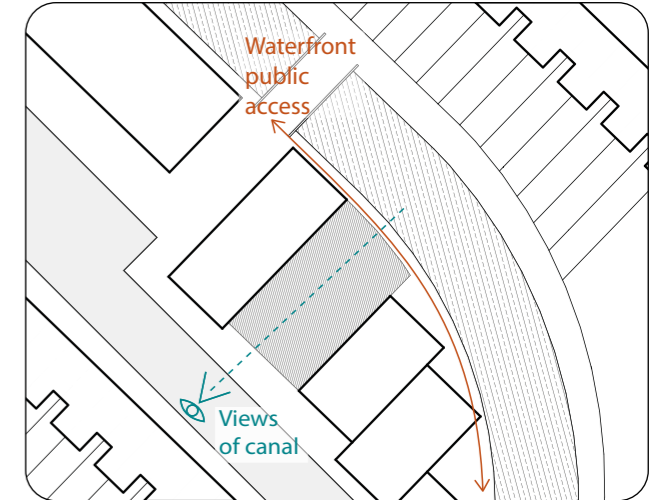

**Design & appearance**

- Developments should seek to optimise layouts to benefit from the access to blue spaces for better daylight/sunlight, ventilation and outlook.
- A number of historically significant structures are located along the waterfront. Developments should seek to enhance these through carefully designed massing and by reflecting some of the proportions or design details.

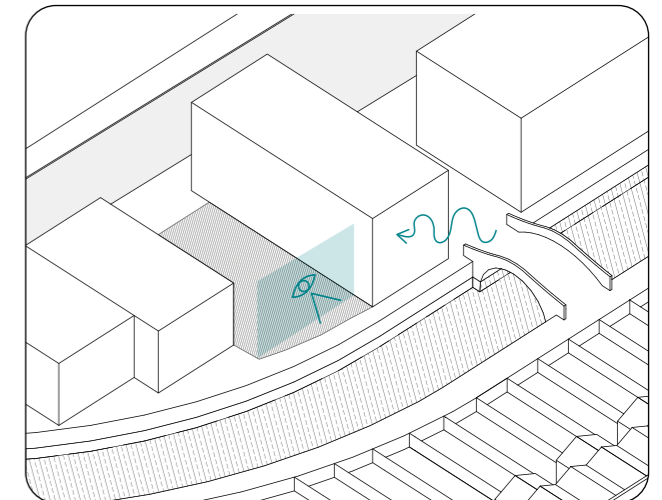

**Footprint & site layout**

- Where appropriate in relation to existing building lines, developments should step back from the edge of the pavement to secure an enhanced public realm.
- The width of the commercial frontage should be maximised.
- Developments should provide wheelchair accessibility through front door.
- Servicing for the commercial unit should seek to minimise any inconvenience for the above residential units.

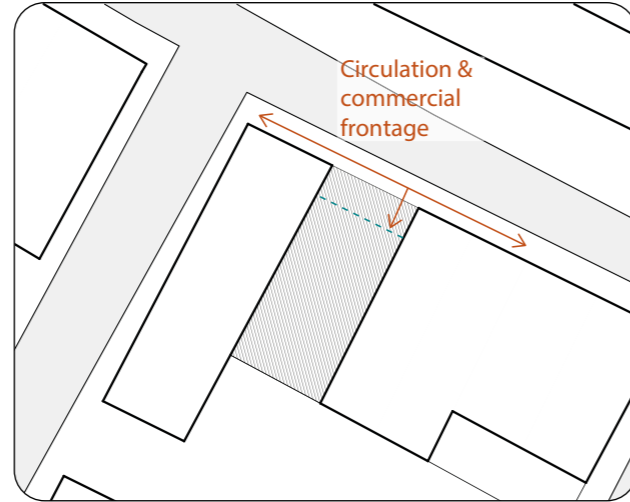

**Design & appearance**

- The design should articulate through visual means different uses on ground floor. For example by differences in materials, set-backs, façade compositions and double-height entrances.
- Building frontage lines often have a direct relationship with the pavement and do not include defensible space. Upper level balconies may need to be inset in order to avoid projecting over the pavement.

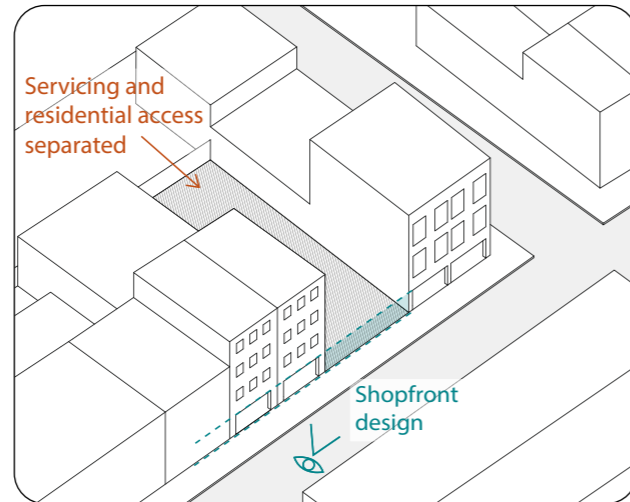

This page is intentionally left blank

# 7. Design principles for residential developments

## 7.1 Introduction

Planning policy requires that new housing developments achieve a high quality of design. This relates both to the quality of internal and external spaces, as well as implementing more sustainable approaches to materials, respecting and responding to the existing surrounding character.

This chapter addresses a number of topics that are regularly raised in regard to design for small sites. As highlighted in the Introduction to the SPD, there are a number of developments that can be classified as small sites. These may include roof/rear extensions to existing buildings and new build developments on sites of up to 0.25 hectares. The guidance therefore applies to both extensions to existing dwellings as well as the creation of new dwellings.

For each of the topics addressed, the chapter presents design principles that should be considered for all residential developments in the Central Area. As the emphasis of the SPD is on small-scale developments, the principles have a particular focus on overcoming usual constraints associated with this type of development in order to achieve high-quality housing. Each design principle is presented in a blue textbox and further information on what the principle entails/how to achieve the principle is found below it in bullet points.

The design principles are based on best-practice architecture and urban design considerations that reflect the council's aspirations. Applicants that do not comply with the guidelines will need to provide robust justification and demonstrate how their proposal meets exceptional design standards, which will be judged on a case-by-case basis.

The design principles should be read in conjunction with **Part A: Character appraisal** of this SPD, as well as chapters 5 - Character-based growth principles and 6 - Design toolkit for small sites. Proposals should respond to the guidelines included in the three chapters forming **Part B: Guidelines for Good Growth**.

Throughout this chapter links to existing policies are highlighted, as well as references that provide further information on specific topics and requirements. Case-studies have been chosen to illustrate each of the design principles. It should be noted, however, that no building is exemplary in all respects and case studies may underperform against other criteria. Captions highlight what is particularly successful about each example.

The list of topics addressed by this chapter is not extensive and applicants are expected to refer to the Tower Hamlets Local Plan 2031 and associated interactive Policies Map to see a full list of policy requirements. If sites are within or adjacent to a conservation area or listed building; would have an effect on a conservation area or listed building (and/or to their settings); or if there is a listed building within the site, applicants should refer to additional heritage guidance such as the Tower Hamlets Conservation Strategy 2027, Conservation Area Character Appraisals and Management Plans, and the Planning (Listed Buildings and Conservation Areas) Act 1990.

## 7.2 Scale and proportions

**Design principle 1:** Developments should be well-proportioned and of a scale that is in keeping with their surroundings.

- Applicants should refer to Chapter 5 - Character-based growth principles to establish and explain whether their development will perform a Reinforcement, Mediation or Reinvention.
- The Central Area is in its majority low-rise, with some taller buildings that are mostly part of estates and their heights should not be used as a precedent for new developments. It will generally be expected of developments that they follow surrounding heights.
- If heights taller than immediate surroundings are proposed, applicants will need to demonstrate how high-quality and innovative design solutions are employed to ensure that development is still in-keeping with context. As noted in the Introduction, this SPD does not apply to tall buildings.
- Existing proportions and positioning of windows, doors and other detailing should inspire new façade designs when contemporary approaches are proposed.
- The proportion between height of development and width of street should be considered to ensure a context-led massing and sense of enclosure. The height of developments should generally be no more than the street width.
- Footprint and massing should be carefully considered so that developments do not hinder future development potential of adjacent/neighbouring buildings or plots.



*Building on the corner that incorporates the same proportions for windows, doors and stairway access of terrace in its contemporary design approach. (photo ©Rory Gardiner)*

### Local Plan policies:

S.DH1: Delivering high quality design  
D.DH2: Attractive streets, spaces and public realm  
S.DH3: Heritage and the historic environment

### 7.3 Relationship with street and public realm

**Design principle 2:** Developments should create a positive relationship with existing streets and public realm.

- In areas where there is a long history of settlements that contributed to the modern street pattern and the building layout, developments should work with the historic settlement pattern where possible so that it remains legible.
- Developments should optimise sites and avoid narrow external, leftover and unusable spaces, particularly as these can attract anti-social behaviour.
- Developments should promote eyes on the street and passive surveillance to public realm, communal and play spaces through careful positioning of openings and active façades. Blank façades on main streets will be resisted.
- The location of main entrances should be informed by the existing street network.
- Greenery should be incorporated into building envelop where possible.
- If site is close to green or blue infrastructure it should prioritise views towards them and improve access through public walkways/paths.
- Permeability and legibility need to be considered at early design stages. This will be particularly relevant where developments are creating new street frontages and/or street pattern where there previously was none (refer to Reinvention in Chapter 5 - Character-based growth principles).

- The boundary between public and private spaces should be clear. Defensible space should be provided even on small and constrained sites. This can be achieved, for example, through building line set-backs, planting, carefully-designed walls and fences. An exception may be made for mews developments with pedestrian-only access and where there is low footfall.
- In areas of substandard air quality applicants should implement mitigation measures to prevent outdoor emissions, such as traffic pollution, being brought inside.



*Diverse planting included within defined defensible space at ground floor provides privacy and improves biodiversity.*

**Local Plan policies:**

- S.DH1: Delivering high quality design
- D.DH2: Attractive streets, spaces and public realm
- S.DH3: Heritage and the historic environment
- D.ES2: Air quality

### 7.4 Mixed uses & mixed tenures

**Design principle 3:** If developments include a mix of tenures and/or other uses such as retail, commercial, or community facilities, these should be carefully integrated into a cohesive design.

- Separate and well-defined access to residential and other uses should be implemented. Separate and well-defined bin and bike storage should also be provided. These aspects need to be considered at early design stages.
- Non-residential uses should preferably be located on lower levels of the development (ideally ground and first floor) to promote active façades and a positive integration between the development and the street.
- Public ground floor uses should be clearly distinguishable from residential uses.
- Appropriate levels of privacy and noise mitigation strategies should be implemented for the residential part of development.
- A servicing strategy for all uses should be developed and agreed at an early stage to ensure adequate urban design is implemented.
- Developments are encouraged to have the same entrance for different tenures. If different entrances are provided, these should be tenure-blind, achieved by them having equal prominence, scale, and the same materials and finishes.
- Communal and play space should be equally accessible by all tenures. Private amenity space should be of equal quality in all tenures.



*The housing scheme has community facilities and a cafe on ground and first floors. These help to activate the façade and to form a positive relationship with the street. (photo ©Jack Hobhouse)*



*The differentiation in the façade makes the separation between the upper and lower floor uses clear. (photo ©Chris Dyson & Peter Landers Photography)*

**Further information:**

LBTH Planning Obligations SPD 2021

**Local Plan policies:**

- S.DH1: Delivering high quality design
- D.DH2: Attractive streets, spaces and public realm
- D.DH8: Amenity

## 7.5 Community

**Design principle 4:** Developments should promote a sense of community and foster community life.

- Developments should seek to incorporate high-quality spaces that promote shared activities between residents and the wider community, such as community rooms, allotments and spaces for gardening. Ideally these should be located on the ground floor/street level to allow for easy access to all residents and a connection with the wider neighbourhood. These spaces should promote and benefit from passive surveillance.
- Internal and external circulation spaces should promote opportunities for residents, particularly those from different tenures and blocks, to cross paths regularly.
- Indoor and outdoor spaces should seek to incorporate furniture that provides opportunities for residents to meet and interact such as picnic benches, notice boards and storage for shared tools and other equipments.
- Small sites present a good opportunity for accommodating community-led housing developments, including those that seek to meet specific needs and/or promote ways of living that are more sociable and adaptable such as intergenerational and co-housing developments.
- If developments are in estate infill sites, it is particularly important to ensure that spaces promote a connection between existing and new residents. Developments should seek to achieve this by including wider improvements to the estate such as on communal areas and outdoor spaces that benefit both new and existing residents.



*The Older Women's Co-Housing is a development of 25 self contained flats with shared communal facilities and gardens, managed on co-housing principles. (photo © Galit Seligmann & Pollard Thomas Edwards)*



*An external communal space that allows for relaxation and play for all ages improves physical and mental health of residents and supports informal encounters between residents (photos ©muf architecture/art)*

### Local Plan policies:

S.SG2: Delivering sustainable growth in Tower Hamlets  
 S.DH1: Delivering high quality design  
 S.H1: Meeting housing needs  
 D.H3: Housing standards and quality

## 7.6 Internal spaces

**Design principle 5:** Developments should comply with housing and accessibility standards and create dwellings with high-quality and flexible internal spaces.

- Dwellings should not only comply with quantitative space requirements, but they should also include internal layouts that allow for flexibility and change over time.
- Dwellings should be dual-aspect and allow for cross-ventilation.
- Orientation and outlook from primary living spaces should be taken into account when laying out floor plans.
- For 2+ bedroom dwellings, separate kitchen and living spaces are encouraged to allow for better, multiple uses of spaces and also to cater for different communities' needs for living and cooking areas. Developments are also encouraged to accommodate provisions for home-working.
- Floor-to-ceiling heights should comply with minimum London standards. Where context allows, higher spaces are encouraged for better daylight/sunlight, ventilation and flexibility, especially in key rooms. Higher ceiling heights (>2.8) will also allow future ceiling fans to be installed to mitigate overheating issues.
- Where flood levels allow, development should provide wheelchair access accommodation on ground floor.

- Basements should preferably only house secondary spaces. If living rooms or bedrooms are proposed in a basement, applicants will need to demonstrate that they comply with appropriate levels of daylight/sunlight and outlook.



*Example of dual-aspect floor plan including inset balcony (7); separation between kitchen (1) and living room (2) if needed, with possibility of cross ventilation through both; flexible twin room (5) which could also be used as a double bedroom; storage space integrated into plan. (image ©Levitt Bernstein)*

### Further information:

GLA Housing SPG 2016  
 GLA Good Quality Homes for all Londoners SPG 2020 (draft)  
 Building Regulations

### Local Plan policies:

S.DH1: Delivering high quality design  
 D.DH8: Amenity  
 S.H1: Meeting housing needs  
 D.H3: Housing standards and quality

## 7.7 External Spaces

**Design principle 6:** Developments should comply with standards for private and communal external amenity space, as well as play space. These should be high-quality outdoor spaces that foster community integration.

- Developments are required to protect or re-provide existing amenity space (private, communal and child play space).
- Major developments are required to provide communal amenity space and play space. These spaces should not only comply with quantitative requirements, but they should also receive good levels of daylight and sunlight, be well-surveilled, easily accessible to all and include an appropriate night-time lighting strategy. Ideally, communal and play spaces should be located on the ground floor/street level. If communal amenity spaces are provided on rooftops, they should have due regard to roof character of surroundings and be overlooked by homes. Play spaces should not be provided on roof tops.
- Close proximity to existing public open spaces should not exempt developments from delivering their own private and communal outdoor spaces.
- Where possible, outdoor spaces should have a southerly orientation to maximise their potential use.
- Outdoor and play space should be designed to meet the needs of the variety of users with a child-friendly and age-friendly design. Developments are encouraged to go beyond minimum space standards to allow for better flexibility and adaptability.

- Flat roofs should be optimised for secondary usage such as urban greening, solar power, outdoor communal amenity space or rainwater harvesting. Pitched roofs should be optimised for secondary usage such as rainwater harvesting or solar power where orientation allows.
- Developments should demonstrate the suitability of the type of private amenity space provided (such as gardens, internal courtyards, roof gardens, projecting balconies or inset balconies). Winter gardens may be considered acceptable in some instances. Design of external spaces and landscaping should be considered at early design stages.

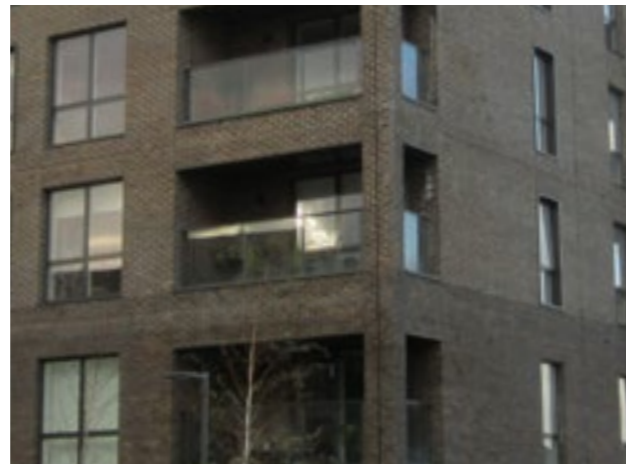

*Inset balconies provide high-quality private amenity space.*

### Further information and guidance:

GLA Housing SPG 2016  
GLA Good Quality Homes for all Londoners SPG 2020 (draft)  
GLA Play and Informal Recreation SPG 2012

### Local Plan policies:

S.DH1: Delivering high quality design  
S.H1: Meeting housing needs  
D.H3: Housing standards and quality

## 7.8 Amenity: light, privacy & outlook

**Design principle 7:** Developments should ensure appropriate levels of amenity to both new and existing dwellings

- Constrained sites should seek innovative solutions such as carefully designed windows, internal courtyards, rooflights and roof gardens to provide adequate levels of daylight/sunlight and privacy.
- Where possible, frosted or tinted glass should be avoided and other design solutions should be prioritised to achieve adequate privacy.
- Outlook should allow for long views where possible, in particular for bedrooms and living rooms, and aim to provide views onto interest spaces and green/blue infrastructure where possible.
- Daylight parameters prescribed by the BRE Standards, such as the 45°/25° test, provide good guidelines for acceptable massing and built form. If proposals do not comply with these parameters, a full daylight/sunlight assessment will be required. The technical assessment should include VSC, NSL, PSH tests. Where gardens/amenity areas are affected, a 2-hour sun contour test should be carried out on 21st March.
- If inset balconies are incorporated, loss of daylight and sunlight to room behind balcony should be mitigated through access solutions such as generous width to window behind balcony; an additional window not placed behind balcony or a shallow room layout.
- Any necessary noise mitigation measures should be considered at early design stages.

- 18m between windows of habitable rooms should be the guiding principle to ensure privacy and avoid unreasonable levels of overlooking. If applicants propose smaller distances, they should demonstrate how the design mitigates privacy and outlook issues. This may be achieved by staggering windows and screening.
- Developments adjacent to schools should avoid overlooking onto school grounds to ensure adequate privacy to minors.



*A combination of carefully-positioned windows, rooflights and internal courtyards ensures privacy and access to light.*  
(photo ©Helene Binet)

### Further information:

BRE Site layout planning for daylight and sunlight: a guide to good practice

### Local Plan policies:

D.DH8: Amenity

## 7.9 Bin and bike storage

**Design principle 8:** Developments should integrate bin and bike storage into the layout and design of the building.

- If not carefully integrated into the development, refuse and bicycles can create clutter on the street scene. Appropriate locations and materiality should be considered from an early design stage to ensure that storage is secure, accessible, weatherproof and that it is integrated into the design and material palette of the proposed development.
- Dedicated external enclosed storage area can keep bins and bikes separate to the home and screened from the street. The store material should be durable and relate to the building design and may be in timber, brick, metal, among others. Sufficient height should be allowed so that lids can be opened fully without having to pull the bins out.
- Communal external bin storage should be positioned and located in a way that it minimises disturbance for streets, green spaces and waterways to avoid causing a negative effect to the use and appearance of these socially important areas.
- The design and location of the waste stores should take account of vehicle and pedestrian circulation. Waste containers should be stored not more than 10m from collection point.
- Developments should consider how the different streams of waste (recycling, household, garden waste and food waste) will be stored, managed and collected.

- Bin storage should be well ventilated to allow for the dispersal of odours.
- Where stores are located within the building envelope, developments should ensure that the design of the façade is not overly dominated by too many servicing doors. Grouping the stores together to the north of the building will improve energy performance.
- For larger developments, applicants should consider the use of underground refuse stores (URS). URS should be located where it avoids the need for servicing from the public highway.
- For roof extensions creating residential units above shops where the current lack of suitable waste storage leads to it presented in bags on the footpath, additional bin storage should be provided within the building envelope. Where this is not possible, the council may consider waste arrangements to match the existing.



*Example of Underground Refuse Stores.*

## 7.9 Bin and bike storage

- Convenient bike storage is a crucial element in encouraging active travel. Developments should provide secure, integrated, convenient and accessible cycle parking facilities to London Plan standards.
- Cycle storage should not require bicycles to be wheeled through living spaces.
- Provision for visitor cycle parking should be made in accordance with the London Plan. This is best provided with cycle racks or stands which are in a well overlooked and accessible location.
- Any additional provision for visitor cycle parking and encouragements for the use of active travel and connections to green grids and cycle routes will be viewed favourably.



*Bin and bike storage integrated into building design with recessed front door. (photo ©Jack Hobhouse & Morris+co)*

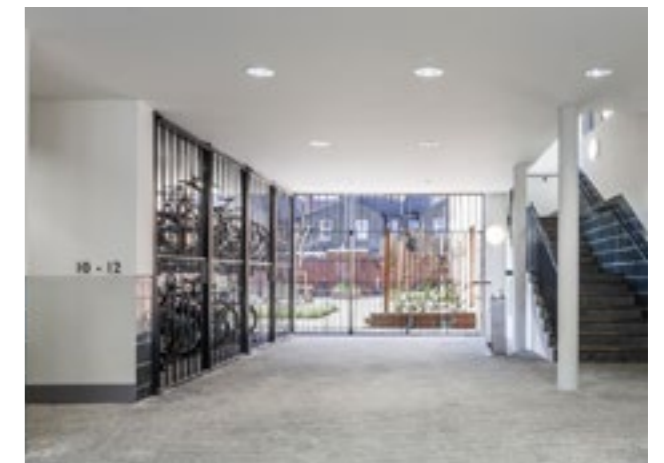

*Bike store integrated into covered entrance in a secure, visible and accessible location. (photo ©Dirk Lindner & Gort Scott)*

**Further information and guidance:**  
LBTH Reuse, Recycling and Waste SPD  
London Plan 2021 (Chapter 10)  
TfL London Cycle Design Standards

**Local Plan policies:**  
D.MW3: Waste collection facilities in new development  
Appendix 3: Parking standards



## 7.10 Materials and detailing

**Design principle 9:** Developments' materials and detailing should be high-quality, durable and sustainable and integrate well with existing palette.

- Materials that are robust and that will weather well should be used, including for cladding, roofing, finishes, fixings and fittings.
- An assessment of the quality of materials of the neighbouring buildings should determine which materials new developments should relate and respond to.
- The use of traditional materials such as brick in contemporary and innovative ways is supported if done in a way that is respectful of context. Ceramic and slate tiles as cladding materials can, for instance, allow for a reinterpretation of more traditional materials.
- If employing contemporary materials, they should complement existing material palette. Employing similar proportions and detailing may be a way of achieving this.
- Metal roofs and wall cladding such as zinc, Cor-Ten, lead and copper are examples of high-quality materials that can integrate well with surroundings and create interesting contrasts.
- Good weathering details are crucial to ensure durability of natural materials such as timber cladding.
- The choice of construction materials (superstructure, substructure, internal finishes, façade and services) based on their embodied and whole life carbon

is viewed favourably (i.e. natural stone, wool insulation, natural rubber flooring and internal timber framing or CLT in buildings below 11m).

- Choice and details of materials should ideally be agreed at pre-application stage.



*Slate wall tiles and timber cladding respond well to surrounding industrial character and brick façades. Good detailing have ensured that the cladding materials have weathered well.* (photo ©Ivan Jones)



*Left: Recycled bricks complement traditional façades.* (photo ©French + Tye & Bradley Van Der Straeten)

*Right: Zinc cladding introduces an interesting contrast to traditional brick façade.* (photo ©Bradley Van Der Straeten)

**Local Plan policies:**  
S.DH1: Delivering high quality design

## 7.11 Sustainable design

**Design principle 10:** Developments should take a fabric-first approach: they should maximise the performance of the components and materials that make up the building fabric itself, before considering the use of mechanical or electrical building services systems.

- Where context and character allows, the building's orientation should be set out so as to minimise energy demand.
- Improved U-values of the external fabric that go beyond regulations are encouraged.
- Maintaining a simple building form and reducing the form factor (ratio of external surface area to the internal floor area) improves energy efficiency.
- Window to façade area ratio should be optimised for most efficient use of daylight/sunlight and ventilation without compromising the building's insulation properties. Wider, shorter windows can improve daylight distribution in rooms. Applicants should consider using architectural features around windows that can make them appear more generous.
- Applicants should mitigate overheating, such as by integrating external solar shading into the façade design: horizontal shading to south and vertical shading to east/west elevations.
- Developments are encouraged to follow passive house principles, including low air tightness rates. Passivhaus certification will be seen favourably.
- Thermal bridging should be minimised, i.e. windows should sit within the

insulation layer. Applicants should consider using enhanced thermal bridging details (see Passivhaus details).

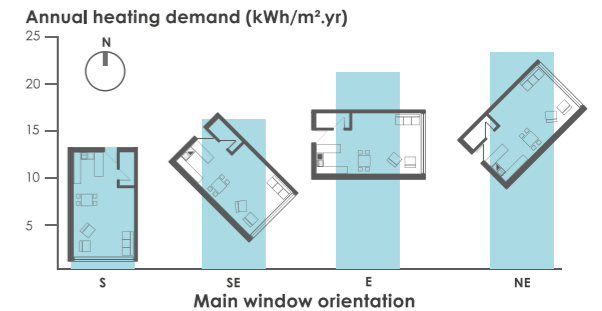

*The diagram shows the impact on space heating demand as the same building is rotated.* (diagram adapted from LETI)

### Fabric U-values (W/m².K)

|                         |                      |
|-------------------------|----------------------|
| Walls                   | 0.13 - 0.15          |
| Floor                   | 0.08 - 0.10          |
| Roof                    | 0.10 - 0.12          |
| Exposed ceilings/floors | 0.13 - 0.18          |
| Windows                 | 1.0 (triple glazing) |
| Doors                   | 1.00                 |

### Window areas guide (% of wall area)

|       |        |       |        |
|-------|--------|-------|--------|
| North | 10-20% | South | 20-25% |
| East  | 10-15% | West  | 10-15% |

*Suggested improved U-values and window to wall areas as set out by LETI.*

**Further information and guidance:**  
LETI Climate Emergency Design Guide  
GLA Sustainable Design and Construction SPG 2014  
GLA Circular Economy Statement Guidance 2020 (draft)  
Good Homes Alliance Overheating in New Homes 2019

### Local Plan policies:

S.ES1: Protecting and enhancing our environment  
D.ES7: A zero carbon borough

## 7.12 Embodied energy

**Design principle 11:** Developments should prioritise low embodied carbon solutions for existing and future buildings.

- Developments are encouraged to choose low embodied carbon materials and systems, based on their life cycle, installation, maintenance, transport, extraction and reuse. Applicants should undertake Whole Life Carbon Assessment to make informed design decisions (e.g. using lime mortar to enable bricks to be recycled in the future).
- Where possible, construction materials should include >30% of materials from re-used sources and >50% materials that can be re-used at end of building life.
- Applicants should consider the adaptability of the design to allow for future changes of occupation and use, as well as the potential end-of-life and disassembly of the building.
- Applicants are encouraged to consider the cleaning and maintenance regime to be undertaken. They should ensure longevity of material and system specifications. They should also consider designing for recycling and deconstruction of Mechanical, Electrical and Plumbing equipment as it is regularly replaced.
- Applicants are encouraged to seek opportunities for off-site construction (on-site construction waste can account for up to 15% of a building's embodied carbon)
- For work to existing buildings (such as extensions or conversions), applicants

are encouraged to improve energy efficiency to existing fabric.

- Applicants are encouraged to carry out an audit of existing buildings and materials on site for Circular Economy purposes. Materials and structures on site should be salvaged and reused where possible.

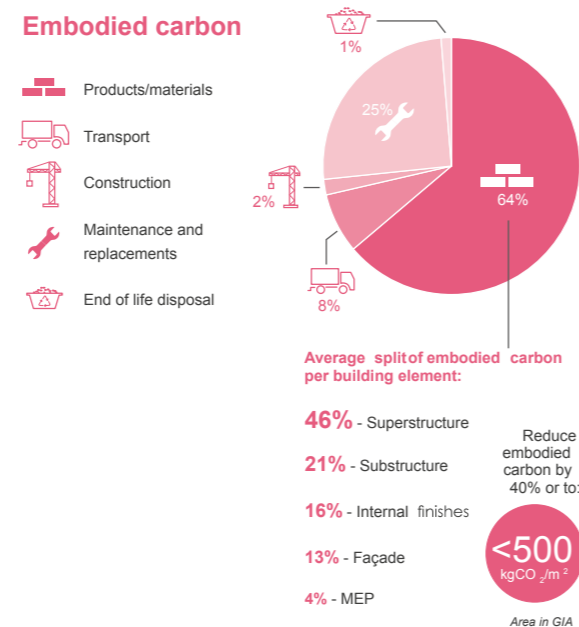

*Breakdown of typical embodied carbon in residential buildings. Focus on reducing embodied carbon for the largest uses.* (diagram ©LETI)

**Further information and guidance:**  
 LETI Climate Emergency Design Guide  
 GLA Sustainable Design and Construction SPG 2014  
 GLA Circular Economy Statement Guidance 2020 (draft)

**Local Plan policies:**  
 S.ES1: Protecting and enhancing our environment  
 D.ES7: A zero carbon borough

## 7.13 Sustainable systems

**Design principle 12:** Developments should integrate sustainable systems in all aspects of design, including energy efficiency, biodiversity, heat and water demand.

- Applicants are encouraged to meet a 35kWh/m<sup>2</sup> a year total energy target and a space heating target of 15kWh/m<sup>2</sup> a year in line with Passivhaus.
- The provision of on-site renewable energy is encouraged such as solar panels or roof-mounted solar thermal panels facing south, east or west.
- Developments should seek to avoid fossil fuel heating systems (e.g. gas boilers and gas CHP). Developments should consider installing heat pumps and/or Mechanical Ventilation with Heat Recovery to reduce heat loss and improve indoor air quality.
- Any external equipment must be shown on plans and elevations to show how they have been integrated into the building design.
- Applicants are encouraged to commit to post-occupancy evaluation studies with measurable data on the building's energy performance.
- Minor developments should seek to achieve the London Plan's principle of no net loss of overall green cover. Major developments should contribute to the greening of London by following the London Plan's Urban Greening Factor. Green cover may be provided by returning hard standing to green space, tree planting, the installation of green roofs and green walls, or the provision of landscaping that facilitates sustainable urban drainage. Developments that go beyond minimum requirements will be

viewed favourably. Green cover should also be used to promote biodiversity.

- Developments are encouraged to exceed water efficiency targets by including non-potable water supply as harvested rainwater or re-used greywater and including sustainable urban drainage systems (SuDS).



*Developments should consider the whole life carbon which encompasses all carbon emissions that arise as a result of the energy used in the construction, operation, maintenance and demolition phases of a building.* (diagram ©LETI)

**Further information and guidance:**  
 LBTH Local Biodiversity Action Plan  
 LBTH Zero Carbon Plan  
 London Plan 2021 (Policy G5: Urban Greening)  
 LETI Climate Emergency Design Guide  
 GLA Urban Greening for Biodiversity  
 Net Gain: a Design Guide 2021  
 GLA Circular Economy Statement Guidance 2020 (draft)

**Local Plan policies:**  
 S.OWS1: Creating a network of open spaces  
 D.OWS3: Open space and green grid networks  
 S.ES1: Protecting and enhancing our environment  
 D.ES3 Urban Greening and biodiversity  
 D.ES5: Sustainable drainage  
 D.ES6 Sustainable wastewater management  
 D.ES7: A zero carbon borough

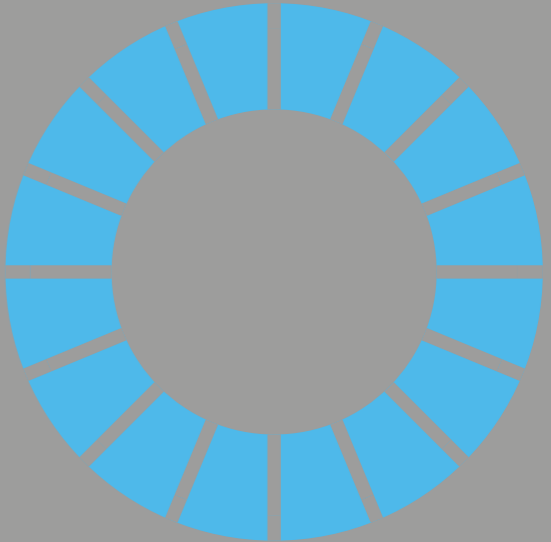
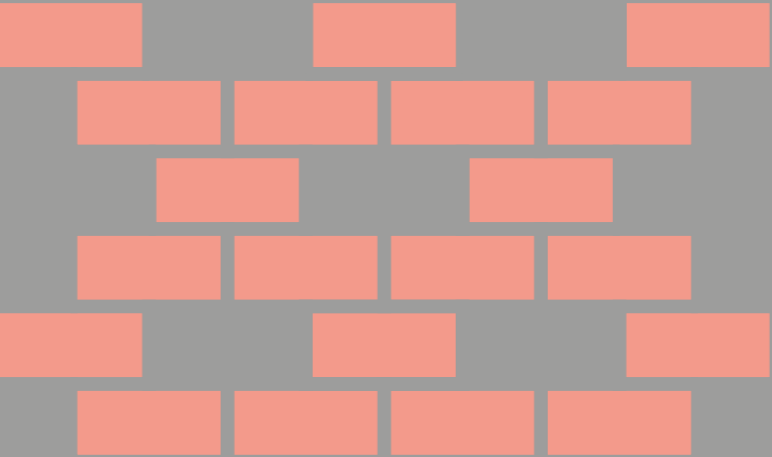
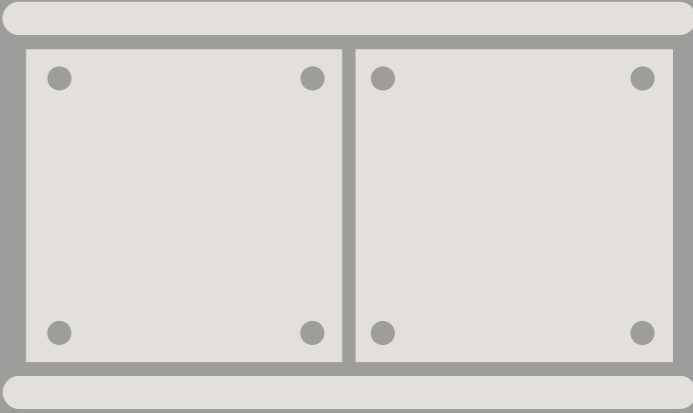
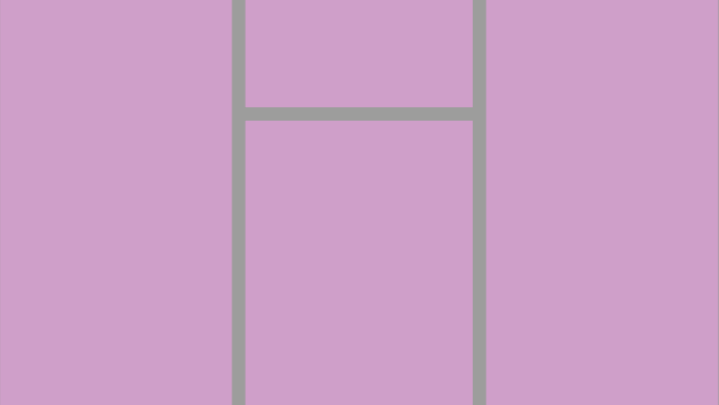

Central Area Good Growth  
Supplementary Planning Document