

Advice Note for New Ventilation Systems

1.0 Introduction

This simple guide to ventilation systems has been drawn to help you fulfil the requirements of the London Borough of Tower Hamlets Pollution Team.

The guide is intended to set out broad requirements and give useful advice. If any works regarding ventilation are required, the advice of a competent qualified ventilation engineer should be sought. If an inadequate system is initially installed, the costs of re-designing a system are usually prohibitive. The most important advice the Council can offer is to get the design right from the beginning!

It is important that the Environmental Health, Food Team and Planning and Building Control Departments are consulted when installing a new ventilation system to ensure their requirements are met. The Council is primarily concerned with three fundamental aspects; these are: -

(a) Odour

(b) Noise

(c) Visual Amenity (Planning Issue)

The advice given hereafter is not intended to be absolute. Continuing advances in modern technology will inevitably mean that new, more efficient systems will come onto the market and possibly supersede the advice given here.

An assumption should be made, however, that the ventilation system detailed in this advice is to be followed unless it can be proved that other methods are more effective in dealing with the problems of odour and noise.

2.0 Typical schematic diagram representing a good ventilation system that might be found in a typical food premises

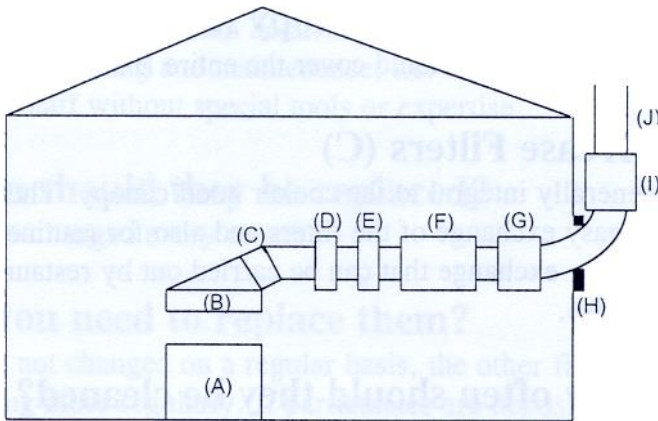

Source: Guidance on the Control of Odour and Noise from Commercial Kitchen Exhaust Systems, DEFRA, 2005

KEY TO FIGURE

- (A) COOKING AREA
- (B) COOKER HOOD/CANOPY
- (C) GREASE FILTERS
- (D) COARSE PRE-FILTER
- (E) FINE PRE-FILTER
- (F) ACTIVATED CARBON FILTERS
- (G) FAN/MOTOR UNIT
- (H) ANTI- VIBRATION MOUNTING
- (I) NOISE ATTENUATOR
- (J) EXHAUST FLUE

Advice

Prior to any scheme being submitted to the Planning Department of the Council, it is recommended that enquiries be made of the Pollution Team over the type of arresting plant to be installed in each case in order to ensure that it is acceptable as far as the Pollution Team is concerned. This should also enable planning application to be processed more speedily.

3.0 Elements of a Good Ventilation System

The diagram on the previous page highlights all the elements of a good ventilation system. Details of each of these elements are given below.

3.1 Cooking Area (A)

An air change rate of between 30 and 60 air changes per hour is acceptable. It is more accurate to specify nominal extract rates for specific kitchen appliances e.g. –

<i>Fryers</i>	500 Litre/second per square metre net area of canopy
<i>Boiling Pans</i>	300 Litre/second per square metre net area of canopy
<i>Ranges</i>	250 Litre/second per square metre net area of canopy

3.2 Cooker Hood/Canopy (B)

The canopy/cooker hood should overhang all cooking equipment by at least 150mm.

3.3 Filtration Equipment

Three stage filtration is generally necessary: grease filters, pre-filters and then carbon filters. Some manufacturers produce a module which includes all three filters in one prefabricated unit.

3.3.1 Grease Filters (C)

The grease filters are generally integral to the cooker hood/canopy. The housing should be arranged for easy exchange of the filters, for routine cleaning and for maintenance according to manufacturer's instructions, so ensuring maximum efficiency. High efficiency grease filters (grease extraction efficiency of at least 95%) should be chosen. A spare set of filters must also be maintained for replacement purposes. The system should never be run without the filters in place. Disposable grease filters should not be used.

3.3.2 Filter Cleaning

If the grease filters are not cleaned on a regular basis, the other filter units in the system will need changing more regularly. If grease/oil is deposited on the carbon filter unit, this will be de-activated very quickly and will soon need replacing. Running costs will be significantly reduced with the proper maintenance and use of the grease filters. It is recommended grease filters are cleaned on a daily basis, baffle type self draining filters may be cleaned on a weekly basis and mesh filters should be cleaned at least twice a week.

3.4 Pre-Filters

Pre-filters trap any particulates which may have got through the grease filters. They are usually fabric based and are disposable. They are intended to protect the relatively expensive carbon filters, thus increasing their life. The pre-filters and carbon filters can be placed inside or outside the building and are located before the fan.

3.4.1 Coarse Pre-Filters (D)

These should be fitted to stop larger particulates escaping through the system. They are often 25mm synthetic pads.

3.4.2 Fine Pre-Filters (E)

These should be fitted to stop finer particles escaping through the system. They are often 50mm pleated elements.

3.4.3 Filter Housing

The filters should be in a panel type housing, arranged for easy exchange of the filters, where routine cleaning and maintenance to the manufacturers instructions can take place, ensuring maximum efficiency. The filters should be fireproofed.

3.4.4 Filter Replacement

Pre-filters should be changed every month. If the pre-filters are not changed on a regular basis, the other filters units in the system will need changing more regularly. If particulates are deposited on the carbon filter unit, this will be de-activated very quickly and will soon need replacing. Running costs will be significantly reduced with the proper maintenance and use of the pre-filters.

3.5 Activated Carbon Filters (F)

The activated carbon filter unit may often consist of (D) and (E) being built into the unit, for ease of installation and manufacture. The entire system should be lagged to prevent cooling and consequential condensation. It is vital that the carbon filters remain dry to ensure their effectiveness. In order for carbon filters to function effectively they need to have adequate unsaturated capacity left and be free from dust or grease contamination. It may be necessary to install a small heater before the carbon filters to ensure that the relative humidity of the air to be treated is kept below 85%.

There are several types of carbon filter available on the market today. Sulphur adsorbing carbon is particularly recommended for kebab or burger bar type takeaways or restaurants. As most cooking fumes/vapour/odour tends to have a high water content, it is also often advisable to use carbon filters with a high water tolerance. Suitable carbon, which fulfils both the above criteria, is Sutcliffe Carbons ST series or an equivalent.

It is important that the air being filtered through the carbon filter system remains in contact with the carbon filter for sufficient time. It should have a low pressure drop (80-100 pa) and a high surface area to improve efficiency. The final choice of fan size will depend on the required "Dwell Time" of a particular carbon filter system.

Advice: The "dwell Time" or "Residence Time" is the period of time the air is in contact with the carbon. For many applications a dwell time of 0.1s is satisfactory but may need to be considerably increased for food with higher odour content.

3.5.1 Filter Housing

The carbon filter housing should be arranged for easy exchange of the filters, for routine cleaning and maintenance to manufacturers instructions to ensure maximum efficiency.

3.5.2 Filter Replacement

Carbon filter systems, despite their supposed "Infinite Life Expectancy", do need changing on a regular basis. Once the adsorption capacity of the carbon filter goes below 60% it will need to be replaced. The required regularity of changing depends on several factors:

(a) The size of the carbon filters, or the "charge" (i.e. how much carbon is there).

(b) The amount of cooking.

Obviously, the smaller the amount of carbon used and the greater the frequency of cooking the sooner the filters would require changing. In practise carbon filters will generally need to be replaced every 4-12 months. In small, high turnover premises every 4- 6 months would be considered normal. Many manufacturers of carbon filters claim that they only need changing once a year; this may help them sell their product but it is not the case.

If the carbon filter system is not working correctly, cooking odours will escape and could give rise to nuisance. *If a nuisance is witnessed a Notice under the Environmental Protection Act 1990, a section 80 notice will be served by the Council on the person responsible.*

3.6 Fan/Motor Unit (G)

Fan(s) and any motor extract ventilation should be installed (with any associated pipework and ducting) in such a way as to prevent transmission of noise and vibration onto adjacent premises. *The fan motor therefore, should be situated INSIDE the premises and a flexible coupling used to prevent transmission of vibration to the ducting.*

3.6.1 Fan Noise

A maximum level of NR (Noise Rating) 35 at a distance of 2m is desirable, particularly if the system is close to residential accommodation. But consideration may need to be given to existing ambient noise in the immediate vicinity of the premises. The Council's policy with regards to plant noise is that the rating level should be 5dB below the existing background noise. The choice of motor needs to be calculated with regard to noise and to the required airflow rates within the system.

3.6.2 Air Flow Rate

This is dependent on many factors, including:

Length of ducting. This needs to account for any elbows/ curves/ junctions/ bends etc. or other added items included within the system, such as the friction throughout the filter system(s). Ducts should not contain any acute right angle bends to ensure smooth flow of air through the ductwork at each change of direction of the duct.

Dwell time required by filtration system. In order for any filtration system to be effective, the air passing through the filters must remain in contact with them for a specified period of time.

Detailed design advice should always be sought by a qualified and competent ventilation engineer.

3.7 Anti- Vibration Mountings (H)

Fan(s) and any motor extract ventilation should be installed (with any associated pipework and ducting) in such a way as to prevent transmission of noise and vibration onto adjacent premises suitable measures may include anti-vibration mountings, flexible couplings and sound reduction measures.

3.8 Noise Attenuator (I)

Noise attenuators/silencers may be required if the fan motor is noisy. Good design practice would require a fan/motor unit that fulfils the requirement of **3.6.1 Fan Noise**. Attenuators should be located after the fan unit.

3.9 Exhaust (J)

The exhaust flue from the system needs to be positioned within the requirements of the Planning Groups' guidelines concerning visual amenity, but normally would be expected to be at least 1 metre above the eaves of the premises and/or above any dormer window. It should be positioned to be as far as possible from the nearest residential accommodation. It is important to avoid discharge into a semi-enclosed area such as a courtyard or the area between back additions. The prevailing wind direction should also be considered in the ducting positioning.

The efflux (terminal discharge) velocity should be at least 15 m/s to provide sufficient dispersal and may require the introduction of a venturi system.

The stack design is paramount to achieving good dispersion and suitable stack designs are discussed overleaf.

The ducting should be rigid in construction to prevent the transfer of noise by vibration. Large section ducts may need bracing or stiffeners to prevent drumming. Wire mesh should be provided at the terminus to prevent pigeons or birds nesting or gaining access.

3.9.1 Best Types of Stack Design -No Caps or Heads

Caps or heads should not be used as they deflect the air stream downwards and also increases duct resistance.

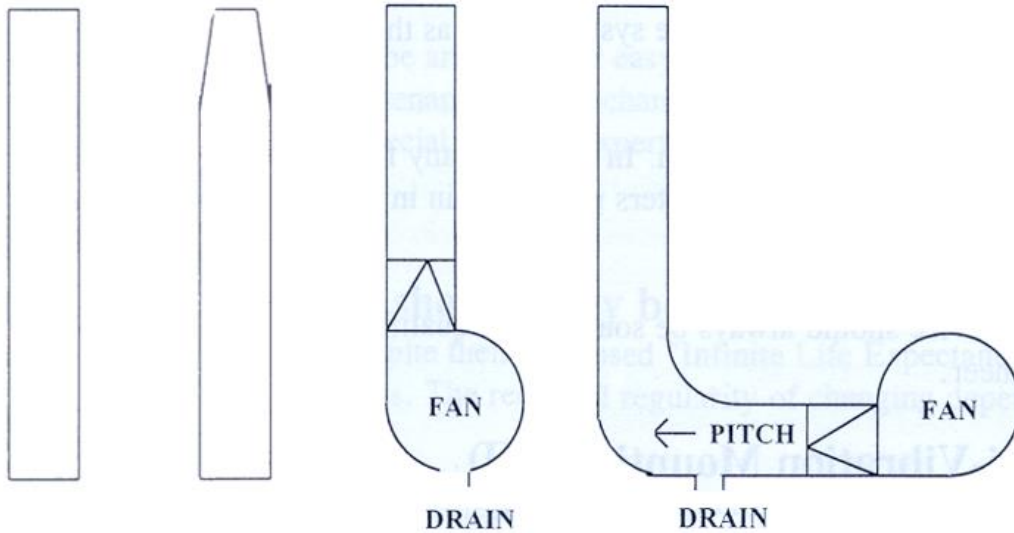

Source: Guidance on the Control of Odour and Noise from Commercial Kitchen Exhaust Systems, DEFRA, 2005

3.9.2 Good Stack Designs

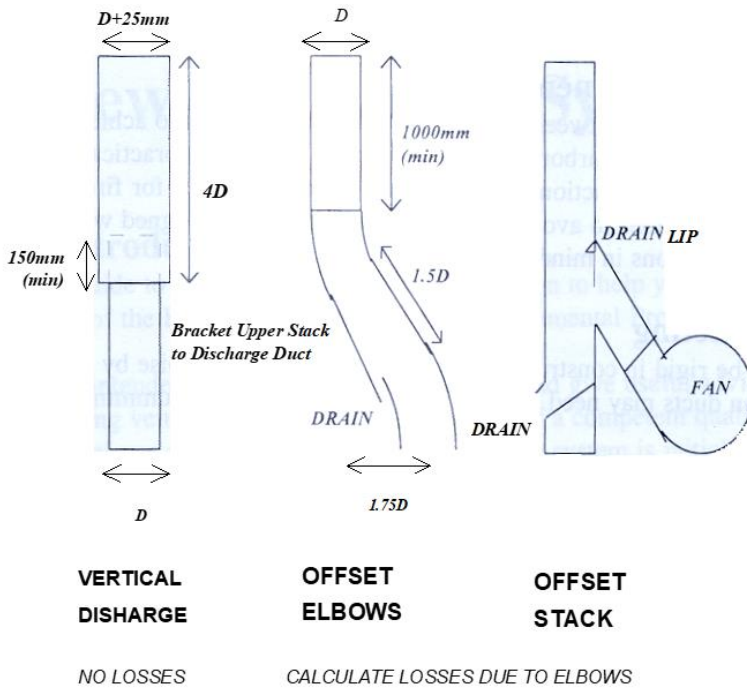

Source: Guidance on the Control of Odour and Noise from Commercial Kitchen Exhaust Systems, DEFRA, 2005

The rain penetration characteristics of these caps are superior to a deflecting cap located 0.75D from the top of the stack. The length of upper stack is related to rain protection. Excessive additional distance may cause "Blow-out" of effluent at the gap between upper and lower sections.

Further Advice

To obtain further advice on this subject please contact the Pollution Team:

Telephone: 020 7364 5008 Email: environmental.protection@towerhamlets.gov.uk